

Installation and Operational Instructions for ROBA-stop[®]-M brake Type 891. _ _ _ . _ Size 1000

(B.8.1.1.GB)

Please read these Operational Instructions carefully and follow them accordingly!

Ignoring these Instructions may lead to malfunctions or to brake failure, resulting in damage to other parts.

These Installation and Operational Instructions (I + O) are part of the brake delivery.

Please keep them handy and near to the brake at all times.

Safety Regulations

These Safety Regulations are user hints only and may not be complete!

General Guidelines

DANGER



Danger of death!
Do not touch voltage-carrying cables and components.

Brakes may generate further risks, among other things:



Hand
injuries



Danger of
seizure



Contact with
hot
surfaces



Magnetic
fields

Severe injury to people and damage to objects may result if:

- the electromagnetic brake is used incorrectly.
- the electromagnetic brake is modified.
- the relevant standards for safety and / or installation conditions are ignored.

During the required risk assessment when designing the machine or system, the dangers involved must be evaluated and removed by taking appropriate protective measures.

To prevent injury or damage, only professionals and specialists are allowed to work on the devices. They must be familiar with the dimensioning, transport, installation, initial operation, maintenance and disposal according to the relevant standards and regulations.



Before product installation and initial operation, please read the Installation and Operational Instructions carefully and observe the Safety Regulations. Incorrect operation can cause injury or damage.

At the time these Installation and Operational Instructions go to print, the electromagnetic brakes accord with the known technical specifications and are operationally safe at the time of delivery.

- Technical data and specifications (Type tags and documentation) must be followed.
- The correct connection voltage must be connected according to the Type tag and wiring guidelines.
- Check electrical components for signs of damage before putting them into operation. Never bring them into contact with water or other fluids.
- Please observe the EN 60204-1 requirements for electrical connection when using in machines.



Only carry out installation, maintenance and repairs in a de-energised, released state and secure the system against inadvertent switch-on.

Guidelines for Electromagnetic Compatibility (EMC)

In accordance with the EMC directives 2004/108/EC, the individual components produce no emissions. However, functional components e.g. mains-side energisation of the brakes with rectifiers, phase demodulators, ROBA®-switch devices or similar controls can produce disturbance which lies above the allowed limit values.

For this reason it is important to read the Installation and Operational Instructions very carefully and to keep to the EMC directives.

Application Conditions



The catalogue values are guideline values which have been determined in test facilities. It may be necessary to carry out your own tests for the intended application. When dimensioning the brakes, please remember that installation situations, braking torque fluctuations, permitted friction work, run-in behaviour and wear as well as general ambient conditions can all affect the given values. These factors should therefore be carefully assessed, and alignments made accordingly.

- Mounting dimensions and connecting dimensions must be adjusted according to the size of the brake at the place of installation.
- The magnetic coils are designed for a relative duty cycle of 100 %.
- The braking torque is dependent on the present run-in condition of the brakes.
- The brakes are only designed for dry running. The torque is lost if the friction surfaces come into contact with oil, grease, water or similar substances or foreign bodies.
- The surfaces of the outer components have been zinc phosphated manufacturer-side to form a basic corrosion protection.

CAUTION



The rotors may rust up and block in corrosive ambient conditions and/or after long periods of storage.

The user is responsible for taking appropriate counter measures.

Safety Regulations

These Safety Regulations are user hints only and may not be complete!

Ambient Temperature: – 20 °C up to + 40 °C

CAUTION



At temperatures of around or under freezing point, condensation can strongly reduce the torque, or the rotors can freeze up. The user is responsible for taking appropriate counter measures.

Appointed Use

mayr[®]-brakes have been developed, manufactured and tested in compliance with the DIN VDE 0580 standard and in accordance with the EU Low Voltage Directive, as electromagnetic components. During installation, operation and maintenance of the product, the requirements for the standard must be observed.

mayr[®]-brakes are for use in machines and systems and must only be used in the situations for which they are ordered and confirmed. Using them for any other purpose is not allowed!

Earthing Connection

The brake is designed for Protection Class I. This protection covers not only the basic insulation, but also the connection of all conductive parts to the PE conductor on the fixed installation. If the basic insulation fails, no contact voltage will remain. Please carry out a standardized inspection of the PE conductor connections to all contactable metal parts!

Insulation Material Class F (+155 °C)

The insulation components on the magnetic coils are manufactured at least to insulation material class F (+155 °C).

Protection

(mechanical) IP54 for Types 891._ _ _ .2:

When installed, dust-proof and protected against contact as well as against water spray from any direction (dependent on customer-side mounting method).

(mechanical) IP65 for Types 891._ _ _ .1:

When installed, dust-proof and protected against contact as well as against jet water from a nozzle coming from any direction (dependent on customer-side mounting method).

(electrical) IP54: Dust-proof and protected against contact as well as against water spray coming from any direction.

Brake Storage

- Store the brakes in a horizontal position, in dry rooms and dust and vibration-free.
- Relative air humidity < 50 %.
- Temperature without major fluctuations within a range from – 20 ° up to +60°C.
- Do not store in direct sunlight or UV light.
- Do not store aggressive, corrosive substances (solvents / acids / lyes / salts etc.) near to the brakes.

For longer storage of more than 2 years, special measures are required (please contact the manufacturers).

Handling

Before installation, the brake must be inspected and found to be in proper condition.

The brake function must be inspected both **once installation has taken place** as well as **after longer system downtimes**, in order to prevent the drive starting up against possibly seized linings.

User-implemented Protective Measures:

- Please cover moving parts to protect **against injury through seizure**.
- Place a cover on the magnetic part to protect **against injury through high temperatures**.
- Protective circuit:** When using DC-side switching, the coil must be protected by a suitable protective circuit according to VDE 0580, which is integrated in mayr[®]-rectifiers. To protect the switching contact from consumption when using DC-side switching, additional protective measures are necessary (e.g. series connection of switching contacts). The switching contacts used should have a minimum contact opening of 3 mm and should be suitable for inductive load switching. Please make sure on selection that the rated voltage and the rated operation current are sufficient. Depending on the application, the switching contact can also be protected by other protective circuits (e.g. mayr[®] spark quenching unit, half-wave and bridge rectifiers), although this may of course then alter the switching times.
- Install additional protective measures **against corrosion** if the brake is subject to extreme ambient conditions or is installed in open air conditions, unprotected from the weather.
- Take precautions **against freeze-up of the friction surfaces** in high humidity and at low temperatures.

Regulations, Standards and Directives Used:

| | |
|-----------------------|--|
| DIN VDE 0580 | Electromagnetic devices and components, general directives |
| 2006/95/EC | Low voltage directive |
| CSA C22.2 No. 14-2010 | Industrial Control Equipment |
| UL 508 (Edition 17) | Industrial Control Equipment |

Please Observe the Following Standards:

| | |
|--------------------------|------------------------------|
| DIN EN ISO 12100-1 and 2 | Machine safety |
| DIN EN ISO 14121-1 | Risk assessment |
| DIN EN 61000-6-4 | Noise emission |
| DIN EN 61000-6-2 | Interference immunity |
| EN 60204-1 | Electrical machine equipment |

Safety Regulations

These Safety Regulations are user hints only and may not be complete!

Liability

The information, guidelines and technical data in these documents were up to date at the time of printing. Demands on previously delivered brakes are not valid.

Liability for damage and operational malfunctions will not be taken if:

- the Installation and Operational Instructions are ignored or neglected.
- the brakes are used inappropriately.
- the brakes are modified.
- the brakes are worked on unprofessionally.
- the brakes are handled or operated incorrectly.

Guarantee

- The guarantee conditions correspond with the Chr. Mayr GmbH + Co. KG sales and delivery conditions.
- Mistakes or deficiencies are to be reported to *mayr*[®] at once!

Conformity Markings

The product confirms to the CE according to the low voltage directive 2006/95/EC

CSA/UL in terms of the Canadian and American standards

Identification

mayr[®] components are clearly marked and described on the Type tag:

Manufacturer

***mayr*[®]**

Name/Type

Article number

Serial number

**Installation and Operational Instructions for
ROBA-stop®-M brake Type 891.
Size 1000**

(B.8.1.1.GB)

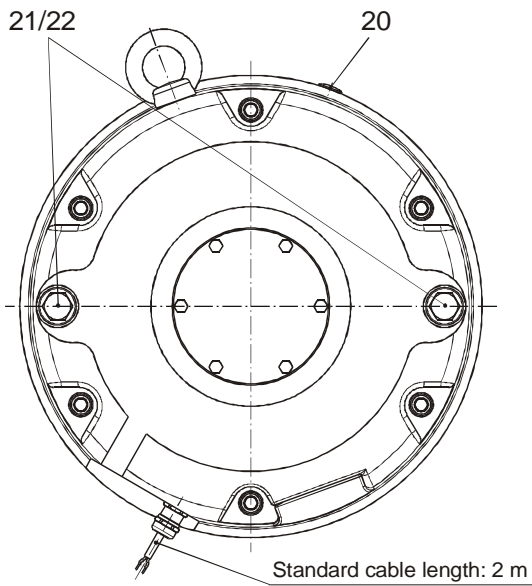

Fig. 1
(Sealed design IP65)

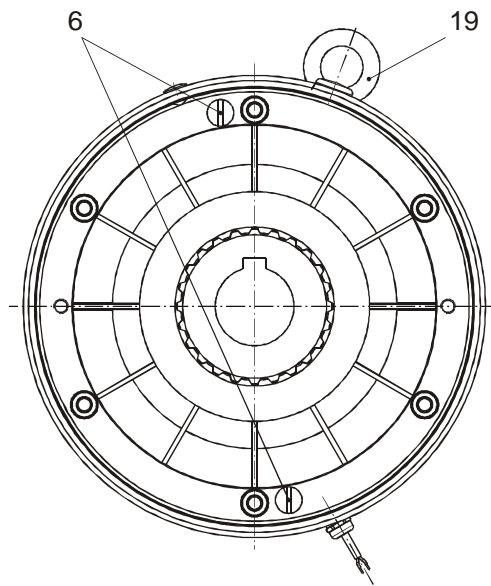

Fig. 2
(Design without flange plate)

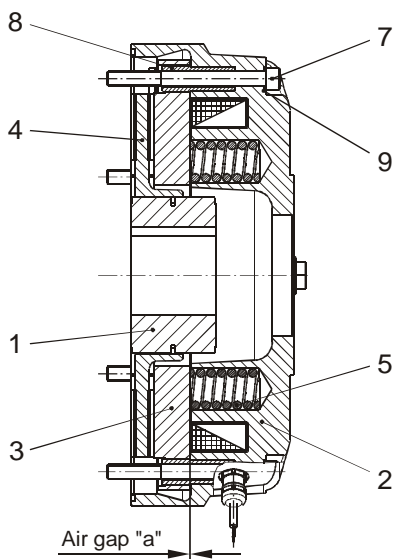

Fig. 3
(Design without flange plate)

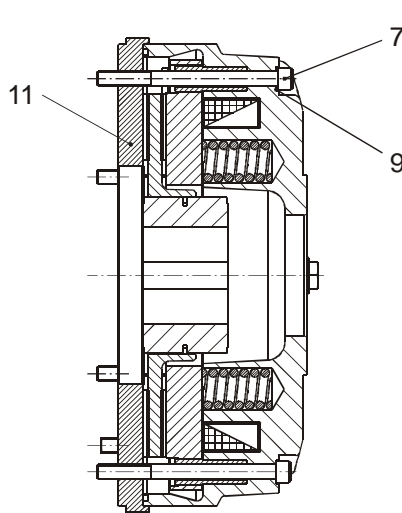

Fig. 4
(Design with tachometer flange plate)

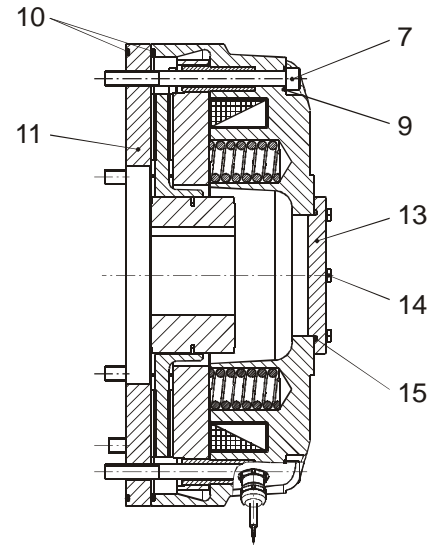

Fig. 5
(Sealed design with flange plate IP65)

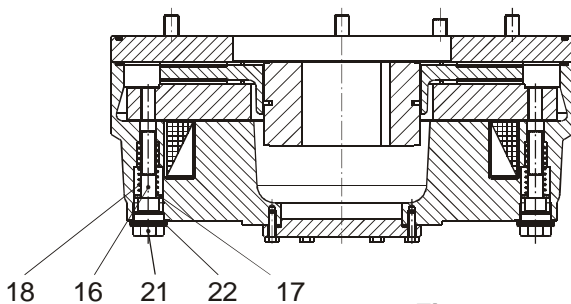

Fig. 6
(Design with emergency hand release)

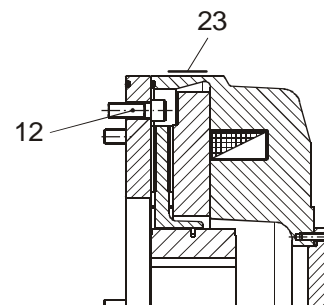

Fig. 7
(Design with flange plate IP65)

Installation and Operational Instructions for ROBA-stop[®]-M brake Type 891. _ _ _ . _ Size 1000

(B.8.1.1.GB)

Parts List (Only use mayr[®] original parts)

| Item | Name | Pcs. |
|------|--|-------------------|
| 1 | Hub | 1 |
| 2 | Coil carrier assembly (with magnetic coil) | 1 |
| 3 | Armature disk | 1 |
| 4 | Rotor | 1 |
| 5 | Thrust spring (Braking torque) | Dependent on Type |
| 6 | Shoulder screw D22 x 55 | 2 |
| 7 | Cap screw M12 x 130 (only on design without flange plate) | 6 |
| | Cap screw M12 x 150 (only on design with flange plate) | 6 |
| 8 | Bushing | 6 |
| 9 | Flat sealing ring (U-seal) D13,7 x 20 x 1,5 | 6 |
| 10 | O-ring D360 x 4 (only on Type 891._ _ _ .1 without flange plate) | 1 |
| | O-ring D360 x 4 (only on Type 891._ _ _ .1 with flange plate) | 2 |
| 11 | Flange plate standard (for Type 891._ _ _ .2) | 1 |
| | Flange plate sealed (for Type 891._ _ _ .1) | 1 |
| 12 | Cap screw M12 x 35 (only on design with flange plate) | 2 |
| 13 | Sealing cover (only on Type 891._ _ _ .1) | 1 |
| 14 | Hexagon head screw M6 x 20 (only on Type 891._ _ _ .1) | 6 |
| 15 | O-ring D100 x 3 (only on Type 891._ _ _ .1) | 1 |
| 16 | Cap screw M12 x 55 (only on design with emergency hand release) | 2 |
| 17 | Washer A13 (only on design with emergency hand release) | 2 |
| 18 | Thrust spring (only on design with emergency hand release) | 2 |
| 19 | Eyebolt M16 | 1 |
| 20 | Screw plug M16 x 1,5 | 1 |
| 21 | Screw plug M26 x 1,5 | 2 |
| 22 | Copper sealing ring D26 x 31 x 2 | 2 |
| 23 | Type tag | 1 |



mayr[®] will take no responsibility or guarantee for replacement parts and accessories which have not been delivered by mayr[®], or for damage resulting from the use of these products.

Installation and Operational Instructions for ROBA-stop®-M brake Type 891. _ _ _ . _ Size 1000

(B.8.1.1.GB)

Table 1: Technical Data

| Type | Standard brake 891.01._._ | Holding brake 891.1._._ |
|--|---|---|
| Nominal braking torque | 1000 Nm | 1600 Nm |
| Braking torque tolerance | +40 % / -20 % | +40 % / -20 % |
| Max. speed | 1500 rpm | 1500 rpm |
| Nominal voltages | 24 V / 104 V / 180 V / 207 V | 24 V / 104 V / 180 V / 207 V |
| P _{nom} electrical nominal power | 160 W | 160 W |
| Electrical connection cross-section | 2 x 0,88 mm ² | 2 x 0,88 mm ² |
| Weight without flange plate | 79 kg | 79 kg |
| Nominal air gap "a" +0,1 / -0,05 (Fig. 3) | 0,5 mm | 0,5 mm |
| Max. permitted air gap "a" after wear (Fig. 3) | 1,6 mm | 1,1 mm |
| Fixing screw Item 7 (Fig. 3) on design without flange plate (Item 11) | 6 x M12 x 130 | 6 x M12 x 130 |
| Fixing screw Item 7 (Figs. 4 and 5) on design with flange plate (Item 11) | 6 x M12 x 150 | 6 x M12 x 150 |
| Cap screws Item 12 (Fig. 7) for flange plate (Item 11) | 2 x M12 x 35 | 2 x M12 x 35 |
| Tightening torque Item 6 | 30 Nm | 30 Nm |
| Tightening torque Item 7 | 83 Nm | 83 Nm |
| Tightening torque Item 12 | 83 Nm | 83 Nm |
| Mass moment of inertia J (hub + rotor on d _{max}) | 424 x 10 ⁻⁴ kgm ² | 424 x 10 ⁻⁴ kgm ² |
| Friction work Q _{r 0,1} (per 0,1 mm wear) | 180 x 10 ⁶ J/0,1 | 90 x 10 ⁶ J/0,1 |
| Friction work Q _{r tot} (max. possible friction work in relation to nominal air gap) | 2000 x 10 ⁶ J | 540 x 10 ⁶ J |
| Rotor thickness, new condition (-0,08 mm) | 18,5 mm | 18,5 mm |
| Minimum rotor thickness (limit value for nominal braking torque) | 17,4 mm | 17,9 mm |
| Permitted hub bores (with keyway acc. DIN 6885) | 75 – 90 mm | 75 – 90 mm |
| Min. width of the counter-friction surface | 35 mm | 35 mm |
| Through holes (coil carrier back) | 100 mm H7 | 100 mm H7 |
| Protection for Type 891._._._.2 | IP 54 | IP 54 |
| Protection for Type 891._._._.1 | IP 65 | IP 65 |
| Ambient temperature | -20 °C to +40 °C | -20 °C to +40 °C |



The stated values Q_{r 0,1} and Q_{r tot} are only approximate values for specific friction work < 0,5 J/mm² and sliding speeds < 10 m/s.

Table 2: Braking Torque Graduations

| Braking torque [Nm] with tolerance +40 % / -20 % | | | | | | | |
|--|--------------------|---|--------------------|--------------------|--------------------|--------------------|-------------------------------------|
| Type 891.08._._ | Type 891.07._._ | Nominal braking torque Type 891.01._._ | Type 891.02._._ | Type 891.03._._ | Type 891.04._._ | Type 891.05._._ | Holding brake Type 891.10._._ |
| 1400 | 1200 | 1000 | 800 | 700 | 500 | 400 | 1600 |

1. Design

ROBA-stop[®]-M brakes are spring applied, electromagnetic safety brakes, which apply a defined braking effect after the voltage is switched off or after a voltage failure.

2. Function

ROBA-stop[®]-M brakes are spring applied, electromagnetic safety brakes.

Spring applied function (brake):

In de-energised condition, thrust springs (5) press against the armature disk (3). The rotor (4) is held between the armature disk (3) and the flange plate (11 / dependent on Type) or the customer-side machine wall via frictional locking.

The braking torque is introduced into the drive line via the toothing of the rotor (4) and the hub (1).

Electromagnetic (release):

Due to the magnetic force of the coil in the coil carrier (2), the armature disk (3) is attracted against the spring force to the coil carrier (2).

The brake is released and the brake rotor (4) with the hub (1) can rotate freely.

Safety brake function:

The ROBA-stop[®]-M brakes reliably and safely in the event of a power switch-off, a power failure or an EMERGENCY STOP.

3. State of Delivery

Please check the state of delivery immediately!

mayr[®] will take no responsibility for belated complaints.

Please report transport damage immediately to the deliverer.

Please report incomplete delivery and obvious defects to the manufacturer.

4. Installation Conditions

- ❑ The eccentricity of the shaft end in relation to the fixing pitch circle must not exceed 0,2 mm.
- ❑ The position tolerance of the threads for the cap screws (7) must not exceed 0,2 mm.
- ❑ The axial run out deviation of the screw-on surface to the shaft must not exceed the permitted axial run out tolerance of **0,125 mm** acc. DIN 42955. The reference diameter is the pitch circle diameter for securement of the brakes. Larger deviations can lead to a drop in torque, to continuous slipping on the rotor (4) and to overheating.
- ❑ The hub bore (1) tolerances and the shaft must be selected so that the hub toothing (1) is not widened. Widening of the toothing leads to the rotor (4) jamming on the hub (1) and therefore to brake malfunctions. Recommended hub - shaft tolerance H7/k6. The max. permitted joining temperature of 200 °C must not be exceeded.
- ❑ The toothings of the hub (1) and the rotor (4) must not be oiled or greased.
- ❑ The rotor (4) and brake surfaces must be oil and grease-free.
- ❑ A suitable counter friction surface (steel or cast iron) must be used. Sharp-edged interruptions on the friction surfaces must be avoided. Recommended surface quality in the area of the friction surface Ra = 1,6 µm.

Customer-side mounting surfaces made of grey cast iron are to be rubbed down additionally with fine sandpaper (grain ≈ 400).

- ❑ Friction value-increasing surface treatments are not permitted.
- ❑ Dimensioning of the key connection according to the requirements shaft diameter, transmittable torque and operating conditions must be carried out. For this, the corresponding user data must be known or the customer must carry out the dimensioning according to the valid calculation basis DIN 6892. For the calculation, a hub quality of Re = 300 N/mm² should be used.
The length of the key should lie over the entire hub.
- ❑ For the dimensioning of the key connections, the permitted tensions common in machine construction must be considered. During initial operation, check whether the key is inserted correctly and whether the cap screws (7) are tightened to a **tightening torque of 83 Nm**.
- ❑ Please abstain from using cleaning agents containing solvents, as they could affect the friction material.
- ❑ During longer downtimes, we recommend the use of suitable corrosion protection measures for the mounting surface (e.g. zinc-phosphate coating) until initial operation.

5. Installation (Figs. 1 and 2)

- 5.1. Mount the hub (1) onto the shaft and bring it into the correct position (the length of the key should lie over the entire hub) and secure it axially (e.g. using a locking ring).
- 5.2. If necessary (dependent on Type), insert the O-ring (10) into the axial groove of the flange plate (11).
- 5.3. If necessary (dependent on Type), guide the flange plate (Item 11 / on Type 891. _ _ _ . 1 inc. O-ring (10)) over the shaft and attach it to the machine wall using 2 cap screws (12) M12 x 35 and a **tightening torque of 83 Nm** (observe the bore alignments in the flange plate (11) to the threaded bores in the machine wall).
- 5.4. Measure the rotor thickness (nominal size dimension in new condition 18,5_{-0,08} mm).
- 5.5. Push the rotor (4) by hand onto the hub (1) (the rotor collar should be facing away from the machine wall or the flange plate (11)). The rotor toothing must lie over the entire length of the hub (1). Check that the toothing moves easily.
- 5.6. If necessary (dependent on Type), insert the O-ring (10) into the axial groove of the coil carrier (2).
- 5.7. Push the rest of the brake over the hub (1) and the rotor collar (4) (the fixing holes should align with the bores on the flange plate (11) or machine wall). The shoulder screws (Item 6 / Fig. 2) prevent the individual components from falling apart. They do not affect the brake function and must not be removed during installation.
- 5.8. Secure the brake evenly all around using the cap screws (7) inc. the manufacturer-side mounted flat sealing rings (9) **with a torque wrench and a tightening torque of 83 Nm**.
- 5.9. Check the air gap, see page 11.

6. Braking Torque Adjustment

The ROBA-stop®-M brakes are set manufacturer-side to the braking torque stipulated on order. Different braking torque adjustments can be made using different spring configurations (5) in the coil carrier (2) (see Table 2). The respective thrust spring set for the requested braking torque adjustment (acc. Table 2) is to be installed at the place of manufacture.

If installation by the user is unavoidable, the required thrust spring set must be ordered stating the exact construction size and braking torque adjustment values.

Thrust Springs (5) Replacement: (Warning: The brake must be load-free)

In order to replace the thrust springs (5), the brake must be unscrewed from the motor bearing shield or from the machine wall.

- 6.1. Remove the fixing screws (7).
- 6.2. Unscrew the shoulder screws (6) from the coil carrier (2) and remove the armature disk (3).
Warning: The thrust springs (5) press against the armature disk (3). In order to remove the shoulder screws (6), the armature disk (3) must be pressed against the coil carrier (2) to avoid immediate relaxation of the thrust springs (5). Observe the installation position of the armature disk (3) and make sure that no thrust springs (5) fall out.

CAUTION



Danger of injury

- 6.3. Replace the thrust springs (5).
Warning: Insert the new thrust spring set in symmetrical order.
- 6.4. Place the armature disk (3) onto the coil carrier (2) or the thrust springs (5) (observe installation position).
- 6.5. Press the armature disk (3) down against the spring force and screw in the shoulder screws (6) up to their limits using a **tightening torque of 30 Nm**.
- 6.6. Screw the brake onto the motor bearing shield or the machine wall using fixing screws (7).
Observe the tightening torque of 83 Nm!

7. Brake Inspection (before brake initial operation)

- **Braking torque inspection:**
Please compare the requested braking torque with the torque stated on the Type tag (23).
- **Carry out a release inspection:**
by energising the brake or by actuating the emergency hand release manually (dependent on Type).

The full set braking torque is not achieved until after the run-in procedure has been carried out.

The braking torque (switching torque) is the torque effective in the shaft train on slipping brakes, with a sliding speed of 1 m/s referring to the mean friction radius (acc. DIN VDE 0580/07.2000).

8. Actuating the Emergency Hand Release (Fig. 3)

DANGER



Before actuating the emergency hand release, ensure that the brake is load-free.

- 8.1. Remove the screw plugs (Item 21 / SW 22) inc. the copper sealing rings (22) on the brake facing side, so that both cap screws (16) become accessible.
- 8.2. Slowly and evenly screw in both cap screws (16) simultaneously using two hexagon socket wrenches SW 10 against the pressure of the thrust springs (18) up to their limits into the armature disk (3) until the brake releases.
- 8.3. Once the emergency hand release has been actuated, both cap screws (16) are screwed out of the armature disk (3) again and the openings are closed again using the screw plugs (21) and copper sealing rings (22).

DANGER



If both cap screws (16) are not completely screwed out of the armature disk (3) again, the function of the brake can no longer be guaranteed.

9. Switching Times

Torque-Time Diagram

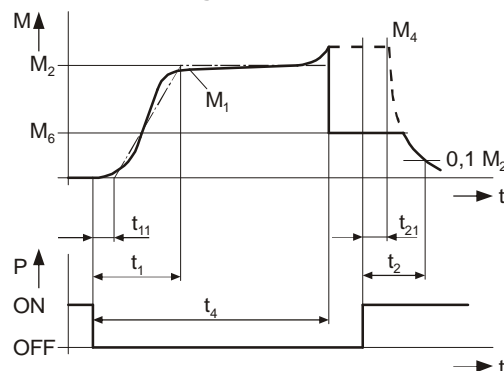

Key:

- M_1 = Switching torque
- M_2 = Nominal torque (characteristic torque)
- M_4 = Transmittable torque
- M_6 = Load torque
- t_1 = Connection time
- t_{11} = Response delay on connection
- t_2 = Separation time
- t_{21} = Response delay on separation
- t_4 = Slipping time + t_{11}

Table 3: Switching Times (on energisation with ROBA®-switch unit and 1,15 s overexcitation)

| | |
|--|---------|
| Separation time t_2 | 270 ms |
| Connection time t_1 DC | 180 ms |
| Connection time t_1 AC | 1200 ms |
| Response delay on connection t_{11} DC | 70 ms |
| Response delay on separation t_{21} | 30 ms |

These values are mean values referring to a nominal air gap and a braking torque (100 %) on a warm brake. For other braking torque adjustments, see the Diagram on page 11: "Separation time t_2 dependent on the spring configuration".

10. Electrical Connection and Wiring



The brake must be operated with overexcitation.

DC current is necessary for operation of the brake. The coil voltage is indicated on the Type tag as well as on the brake body and is designed according to the DIN IEC 60038 ($\pm 10\%$ tolerance). The brake must only be operated with overexcitation (e.g. with a ROBA[®]-switch or -multiswitch fast acting rectifier or phase demodulator). Dependent on the brake equipment, the connection possibilities can vary. Please follow the exact connections according to the Wiring Diagram. The manufacturer and the user must observe the applicable directives and standards (e.g. DIN EN 60204-1 and DIN VDE 0580). Their observance must be guaranteed and double-checked!

Earthing Connection

The brake is designed for Protection Class I. This protection covers not only the basic insulation, but also the connection of all conductive parts to the PE conductor on the fixed installation. If the basic insulation fails, no contact voltage will remain. Please carry out a standardized inspection of the PE conductor connections to all contactable metal parts!

Device Fuses

To protect against damage from short circuits, please add suitable device fuses to the mains cable.

Switching Behaviour

The operational behaviour of a brake is to a large extent dependent on the switching mode used. Furthermore, the switching times are influenced by the temperature and the air gap between the armature disk and the coil carrier (dependent on the wear condition of the linings).

Magnetic Field Build-up

When the voltage is switched on, a magnetic field is built up in the brake coil, which attracts the armature disk to the coil carrier and releases the brake.

• Field Build-up with Normal Excitation

If the magnetic coil is energised with nominal voltage, the coil voltage does not immediately reach its nominal value. The coil inductivity causes the current to increase slowly as an exponential function. Accordingly, the build-up of the magnetic field takes place more slowly and the braking torque drop (curve 1) is also delayed.

• Field Build-up with Overexcitation

A quicker and safer drop in braking torque is achieved if the coil is temporarily placed under a higher voltage than the nominal voltage, as the current then increases more quickly. Once the brake is released, it needs to be switched over to the nominal voltage (curve 2). The ROBA[®]-(multi)switch fast acting rectifier and phase demodulator work on this principle.

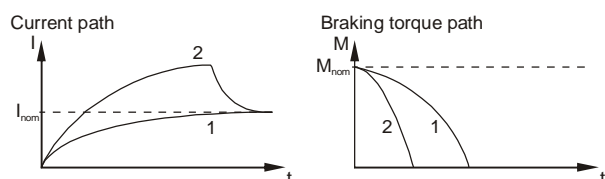

Operation with overexcitation requires an inspection of :

- The required overexcitation time*
- The RMS coil capacity** with a cycle frequency larger than 1 cycle per minute.

* Overexcitation time t_{over}

Increased wear, and therefore an increasing air gap as well as coil heating lengthen the separation time t_2 for the brake. For this reason, at least double the separation time t_2 must be selected for nominal voltage t_{over} .

The spring forces also influence the brake separation times t_2 : Higher spring forces increase the separation times t_2 and lower spring forces reduce the separation times t_2 . Please observe the Diagrams on page 11.

• Spring force (braking torque adjustment) < 100 %:

The overexcitation time t_{over} is less than the doubled separation time t_2 .

• Spring force (braking torque adjustment) = 100 %:

The overexcitation time t_{over} equals the doubled separation time t_2 .

• Spring force (braking torque adjustment) > 100 % / holding brake:

The overexcitation time t_{over} is higher than the doubled separation time t_2 .

** RMS coil capacity P_{RMS}



$$P_{RMS} \leq P_{nom}$$

The coil capacity P_{RMS} must not be larger than P_{nom} . Otherwise the coil may fail due to thermal overload.

Calculations:

P_{RMS} [W] RMS coil capacity dependent on switching frequency, overexcitation, reductions in capacity and duty cycle

$$P_{RMS} = \frac{P_{over} \times t_{over} + P_{hold} \times t_{hold}}{t_{tot}}$$

P_{nom} [W] Coil nominal capacity (Catalogue information, Type tag)

P_{over} [W] Coil capacity on overexcitation

$$P_{over} = \left(\frac{U_{over}}{U_{nom}} \right)^2 \times P_{nom}$$

P_{hold} [W] Coil capacity at reduced capacity

$$P_{hold} = \left(\frac{U_{hold}}{U_{nom}} \right)^2 \times P_{nom}$$

t_{over} [s] Overexcitation time

t_{hold} [s] Time of operation with reduction in capacity

t_{off} [s] De-energised time

t_{tot} [s] Total time ($t_{over} + t_{hold} + t_{off}$)

U_{over} [V] Overexcitation voltage (bridge voltage)

U_{hold} [V] Holding voltage (one-way voltage)

U_{nom} [V] Coil nominal voltage

Time Diagram

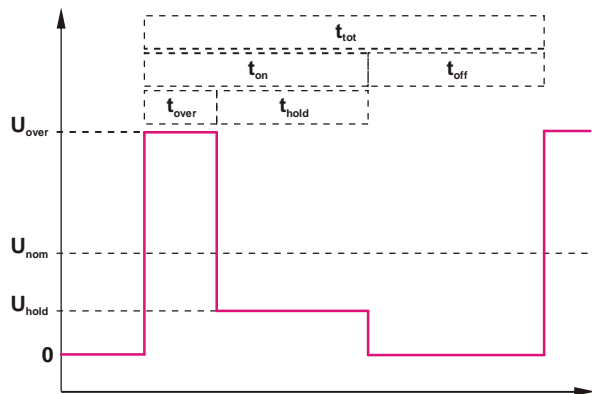
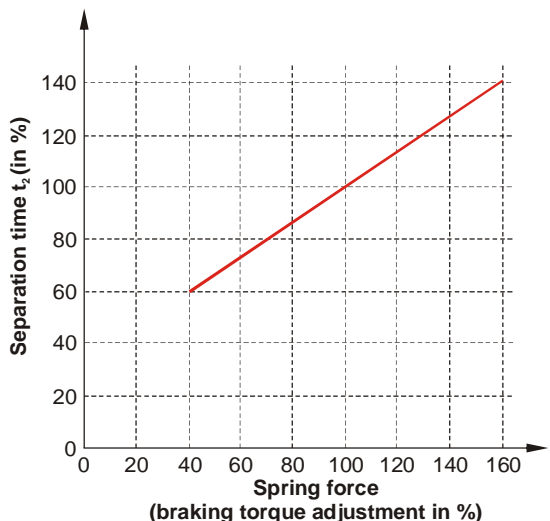

Diagram: Brake separation time t_2 dependent on the spring configuration



For the holding brake, 160 % spring force should be applied.

Magnetic Field Removal

• AC-side Switching

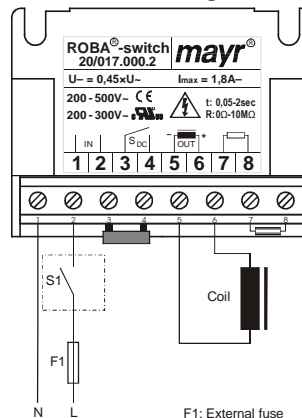

The power circuit is interrupted before the rectifier. The magnetic field slowly reduces. This delays the rise in braking torque.

When switching times are not important, please switch AC-side, as no protective measures are necessary for coil and switching contacts.

AC-side switching means **low-noise switching**; however, the brake engagement time is longer (c. 6-10 times longer than with DC-side switching). Use for non-critical brake times.

• DC-side Switching

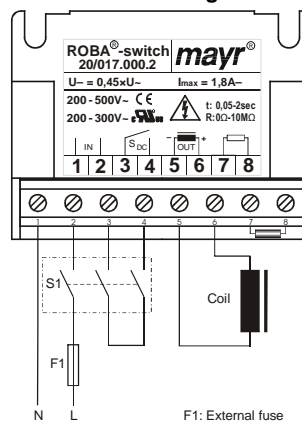

The power circuit is interrupted between the rectifier and the coil as well as mains-side. The magnetic field reduces extremely quickly. This causes a quick rise in braking torque.

When switching DC-side, high voltage peaks are produced in the coil, which lead to wear on the contacts from sparks and to destruction of the insulation.

DC-side switching means **short brake engagement times** (e.g. for **EMERGENCY STOP**); however, louder switching noises.

Protective Circuit

When using DC-side switching, the coil must be protected by a suitable protective circuit according to VDE 0580, which is integrated in *mayr*[®] rectifiers. To protect the switching contact from consumption when using DC-side switching, additional protective measures are necessary (e.g. series connection of switching contacts). The switching contacts used should have a minimum contact opening of 3 mm and should be suitable for inductive load switching.

Please make sure on selection that the rated voltage and the rated operation current are sufficient.

Depending on the application, the switching contact can also be protected by other protective circuits (e.g. *mayr*[®] spark quenching unit, half-wave and bridge rectifiers), although this may of course then alter the switching times.

11. Air Gap Inspection

The air gap can be checked using the feeler gauge, which must be inserted at least 50 mm deep (see Fig. 8), so that the distance between the armature disk (3) and the coil carrier (2) is measured.

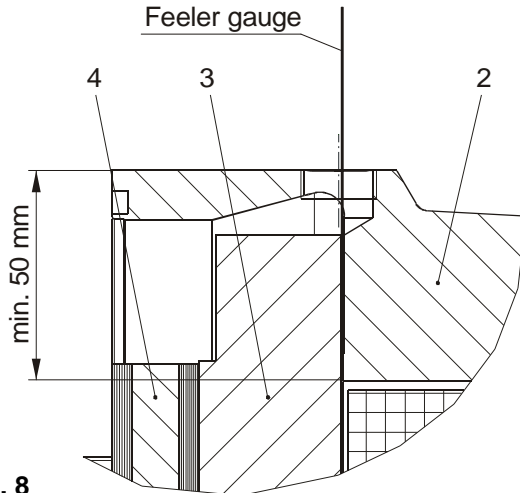

Fig. 8

12. Maintenance

ROBA-stop® -M brakes are mainly maintenance-free. The rotor (4) is robust and wear-resistant. This ensures a particularly long lifetime. However, it is of course subject to operational wear. If the rotor (4) does become worn and the function of the brake can no longer be guaranteed, the brake can be re-set to its functional state via rotor replacement. Please check the quality of the counter friction surface. The wear condition of the rotor (4) can be specified by:

- checking the air gap (see section 11).
For the maximum permitted air gap, see Table 1 on page 7.
- measuring the release voltage.
The release voltage may be up to max. 90 % of the overexcitation voltage on a warm brake.
- measuring the rotor thickness on the dismantled brake.

The amount of wear on the rotor (4) must be examined during the regular inspection intervals:

**At least half-yearly or
at the latest after 1000 operating hours.**

The inspection should include:

- Inspection of the rotor thickness (wear).
- Inspection of the toothings of the rotor (4) and the hub (1) for ease of movement, increased backlash and damage.
Max. permitted rotor torsional backlash on the hub → 0,3 °
(equals c. 0,8 mm on the circumference).
Inspection of engaged brake and load-free output by turning the motor shaft.
- Inspection of the armature disk (3) and the flange plate (11) or the friction surfaces of the motor plate for plane parallelism and wear (excessive formation of grooves).
- Clean the brake.

Wear times are influenced by many factors and can vary substantially. The required inspection and maintenance intervals must be calculated individually according to the system manufacturer's planning documentation.

Replacing the Rotor (4):

DANGER



The brake must be load-free. Please check that it is load-free before de-installation. In order to replace the rotor (4), the brake must be unscrewed from the motor bearing shield or from the machine wall.

- 13.1 Remove the fixing screws (7).
- 13.2 Remove the brake and clean it. Remove abraded particles using compressed air (use an industrial vacuum / wear a dust mask).
- 13.3 Remove the rotor (4) from the hub (1).
- 13.4 Check the hub (1) for damage and replace it if necessary.
- 13.5 Check the armature disk (3) and the counter friction surface for signs of wear and plane parallelism 0,08 mm. There must be no excessive formation of grooves. Replace the armature disk (3) and the flange plate (11) if necessary.
For replacement or installation of the armature disk (3), see sections 6.2, 6.4 and 6.5.
For replacement and installation of the flange plate (11), see sections 5.2 and 5.3.
- 13.6 Measure the rotor thickness of the new rotor (4).
Nominal size dimension 18,5_{-0,08} mm.
- 13.7 Push the rotor (4) onto the hub (1) and check for radial backlash. If there is a larger amount of backlash in the toothing between the hub (1) and the rotor (4), the hub (1) must be removed from the shaft and replaced.
- 13.8 Screw the brake onto the motor bearing shield or the machine wall using fixing screws (7) (please observe the tightening torque of **83 Nm**).
- 13.9 For brake inspection and run-in procedure, please see section 7 on page 9.



On brakes with reduced braking torque and / or operating with fast-acting rectifiers, unpermittedly high wear values will not be noticed via the brake switching behaviour, as the magnetic coil is, in this case, capable of allowing a very large tension path for the armature disk (3). Unpermittedly high wear relaxes the thrust springs (5), leading to a drop in torque.

13. Permitted Brake Friction Work

The permitted friction work values dependent on the switching frequency shown in the characteristic curves must not be exceeded, not even in EMERGENCY STOP operation.

The following diagrams show the permitted friction work values Q_r , referring to the respective switching frequency for the various brake sizes and rated speeds.



For 60 Hz operation, the max. permitted friction work values must be reduced to 80 %.

Friction Power Diagram 1 for Type 891.01 _ _ :

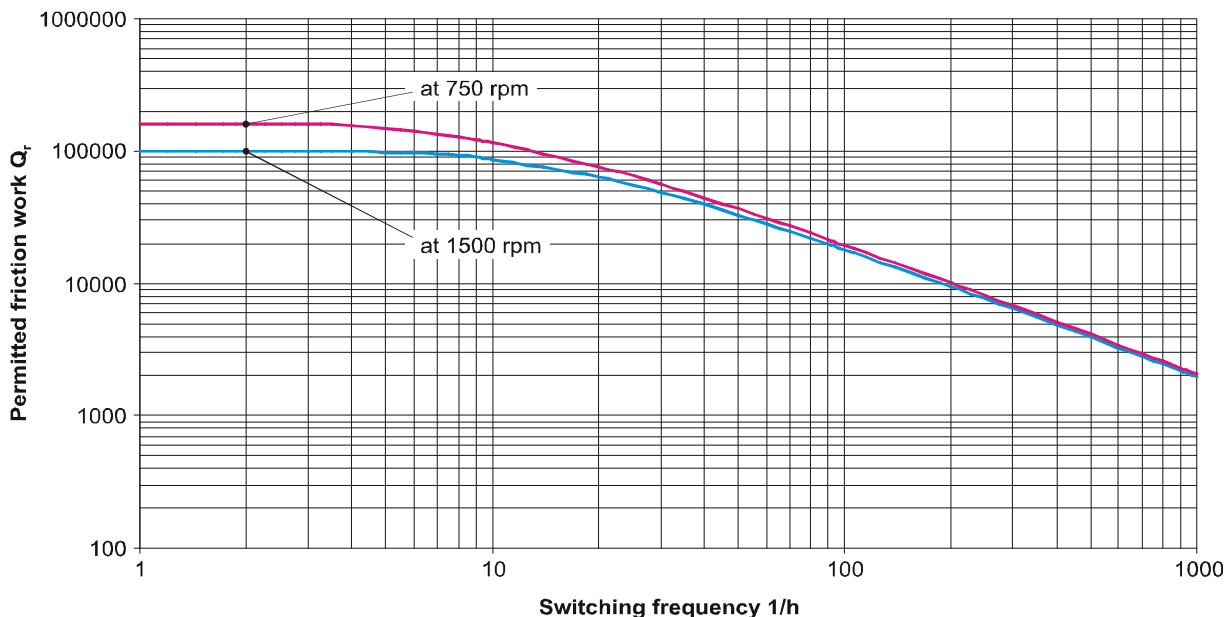

Friction Power Diagram 2 for Type 891.10 _ _ :

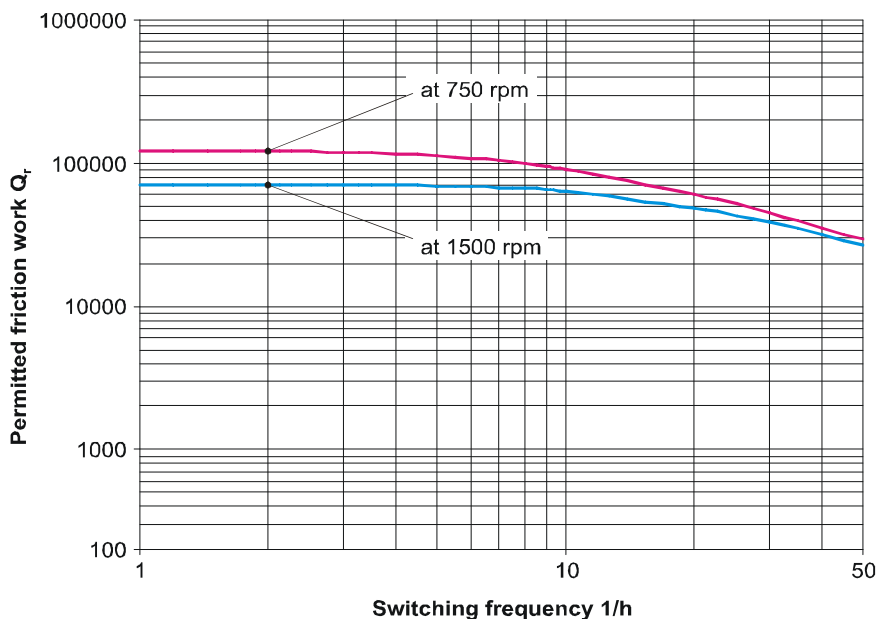

Installation and Operational Instructions for ROBA-stop®-M brake Type 891. _ _ _ . _ Size 1000

(B.8.1.1.GB)

14. Disposal

Our electromagnetic brake components must be disposed of separately as they consist of different materials. Please observe the relevant authority regulations. Code numbers may vary according to the dismantling process (metal, plastic and cable).

Electronic components

(Rectifier / ROBA®-switch / Microswitch):

Products which have not been dismantled can be disposed of under the Code 160214 (mixed materials) or components under Code. No. 160216, or can be disposed of by a certified disposal firm.

Brake bodies made of steel pads with coil / cable and all other steel components:

Steel scrap (Code No. 160117)

All aluminium components:

Non-ferrous metals (Code No. 160118)

Brake rotor (steel or aluminium pads with friction linings):

Brake linings (Code No. 160112)

Seals, O-rings, V-seals, elastomers, terminal boxes (PVC):

Plastic (Code No. 160119)

15. Malfunctions / Breakdowns

| Malfunction | Result of Malfunction | Possible Causes | Solutions |
|---|--|--|--|
| | | | <input type="checkbox"/> Always dismantle the brake for repair of damage or inspection of malfunctions. <input type="checkbox"/> Damaged parts must be replaced in order to solve the respective problem. <input type="checkbox"/> The brake must be cleaned before re-installation. |
| The brake does not release completely; permanent grinding on the rotor | The axial flexibility of the rotor is limited, rotor is jammed axially | Incorrect tolerance constellation on the shaft-hub connection | Check tolerances |
| | | Tolerance errors on the key connection | |
| | | Broken hub due to installation error when mounting | Suitable mounting method |
| | | Poor shaft quality | Check the shaft quality |
| | | Poor key dimensioning | Carry out a key calculation |
| | | Hub toothing dirty due to abraded or worn particles | Check the hub and rotor toothing, maintain suitable maintenance intervals |
| | | Worn, knocked out hub and rotor toothing | |
| | | Toothing breakage | |
| Damaged, deformed hub and rotor toothing | | | |
| The brake does not release completely; permanent grinding on the rotor | Wiring error on the brake | Incorrect voltage, no DC voltage | Check voltage, observe the wiring guidelines |
| | | Defective electrical wiring | Check electrical wiring |
| | | Defective coil, electric coil is electrically, thermally overloaded | Check coil capacity; check insulation resistance |
| The brake does not release completely; permanent grinding on the rotor | Air gap too small in released condition | Due to installation | Air gap inspection |
| | | Penetration of foreign bodies into the brake, in particular magnetisable particles | Check the brake interior for dirt and clean it |
| | | Excessive component temperatures, temperature expansion | Temperature inspection |

15. Malfunctions / Breakdowns

| Malfunction | Result of Malfunction | Possible Causes | Solutions <input type="checkbox"/> Always dismantle the brake for repair of damage or inspection of malfunctions. <input type="checkbox"/> Damaged parts must be replaced in order to solve the respective problem. <input type="checkbox"/> The brake must be cleaned before re-installation. |
|--|--|---|--|
| Slipping, permanent grinding of the brake under load, increase in friction work | Braking torque too low | Incorrect dimensioning | Check the required braking torque |
| | | Incorrect spring configuration | Check the spring configuration; have the brake checked at the place of manufacture |
| | Drop in braking torque | Excessive wear on the rotor | Wear inspection |
| | | Changes to the friction behaviour on the friction lining due to the max. permitted sliding speed being exceeded | Check for correct wiring, switching times and dimensioning |
| | Changes in braking torque | Unpermittedly high friction work, squeaking, type and quality of the counter friction surface | Check for correct wiring, switching times and dimensioning |
| | | Corrosion on the counter friction surface | Check the brake for corrosion |
| | | Ambient influences, oil water, cleaning media, condensation formation | Check that the device is protected from environmental influences |
| | | Type and quality of the counter friction surface | Check the counter friction surface |
| | Brake cannot be released | Extremely low friction speeds | Check the dimensioning |
| | | Excessive tension path due to unpermitted wear | Wear inspection; replace the rotors |
| Increased friction work, brake grinds | Excessively long engagement times | Load accelerates the drive line during the brake engagement time | Check for correct wiring, switching times and dimensioning |
| | Drop in braking torque | Excessive wear on the rotor | Wear inspection; replace the rotors |
| | Motor starts up against closed brake | Excessive brake traction times | Check for correct wiring, switching times; check dimensioning; check motor controls |
| Component breakage | Operating conditions | Oscillations, vibrations, overload, unpermittedly high speeds | Check operating conditions and dimensioning |
| | Ambient influences, temperature, fluids, media, corrosion | Friction linings sticking, settling or swelling; changes in friction lining friction behaviour | Check that the device is protected from environmental influences |
| | Deviations, adjustment dimensions and the screw tightening torques | Brake securement, hand release, actuation lever, screws | Check the guidelines and values according to the information in the Installation and Operational Instructions |



mayr® will take no responsibility or guarantee for replacement parts and accessories which have not been delivered by mayr®, or for damage resulting from the use of these products.