

Elevator Brakes

Highest safety with mayr[®]-brakes
according to EN 81 and ASME A17



www.mayr.de

IMG.800.V05.GB

mayr[®]
your reliable partner

Construction and Development

We Always Have the Better Solution

With our innovative and economical solutions, we are able to set new records in the field of power transmission. Our ambition to always develop better solutions has made our company well-known worldwide.

Highly qualified engineers, high-performance 3D-CAD-systems and the most up-to-date FEM calculation aids used in our Development and Construction departments mean that our business is perfectly equipped to offer our customers effective solutions.



Experts for all Power Transmission Questions

Exploit our know-how, gained by decades of experience in the development, production and application of power transmission products. Our experts in Construction and Development are happy to advise you personally and competently when selecting and dimensioning the drive solution you require.

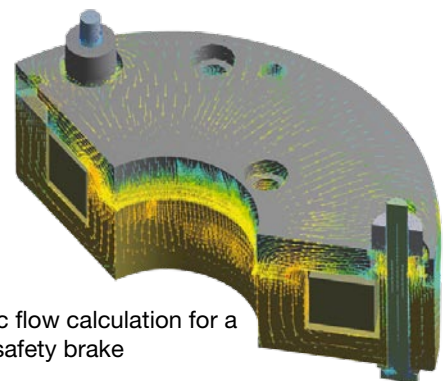

FEM-magnetic flow calculation for a ROBA-stop® safety brake

From Prototype to Finished Product

No mayr® product is released onto the market until it has proven its functional capabilities and reliability in extreme, long-term test.

The spectrum of testing stands is as varied as our range of products:

- Friction work test stands
- Wear test stands
- Noise measurement room with highly accurate noise measurement inspection devices
- Torque measurement stands up to 200.000 Nm
- Impact and alternating load test stands
- Force test stands
- Linear movement test stands
- Continuous performance test stands
- Magnetic flow measurement test stands
- High-speed test stands up to 20.000 rpm
- Misalignment and angular misalignment test stands
- Load and measurement test stands for DC motors

Product Data: Our 24-hour Service

Our website offers you detailed information 24 hours per day, 365 days per year with no delays. Here you can find not only the latest catalogues and technical documentation, but also CAD-files for cost-saving construction of our products.



100 % quality: Before delivery, every single brake is checked and the results are recorded.

Perfect elevator brakes for

- Gearless elevator machinery
- Conventional drive concepts
- Motor attachment
- Traction sheave attachment
- Retrofitting

Trust in the reliability and expertise of the worldwide market leader!

Low-noise – and have proven their worth a thousand times

Elevator brakes by *mayr*[®] power transmission comply with the highest safety requirements acc. EN 81 or acc. TRA 200 and are unbeatably quiet. Their compact design allows innovative possibilities or economic solutions.

Furthermore, we offer optimum control devices for all elevator brakes. They are adapted to the respective type and supplement the brakes perfectly.

Your advantages:

- Largest variant selection for all elevator drives
- Low-noise operation
- Simple installation and inspection
- World-wide service and availability

Contact us!

We have the perfect safety brake for your elevator drive.

Safety requires a reliable and competent partner

Where safety is concerned, compromises are out of the question. *mayr*[®] power transmission is your reliable and competent partner for the development, production and implementation of safety brakes for all elevator concepts and all drive variants. We offer innovative, state-of-the-art technology and local representation in every important industrial region worldwide. Based on 40 years of know-how in the field of safety brakes, our experience with thousands of different applications and our extensive product range, we are able to offer you the perfect, cost-effective and extremely low-noise solution for your specific demands.



ROBA®-duplostop®

The safety brake in a double package for gearless drives

The ROBA®-duplostop® consists of two individual, rectangular brake magnets, which are positioned next to one another. Therefore, it has an extremely short construction length in comparison to systems with brakes that are positioned end-to-end. The compact constructive design makes installation and handling easier. The working air gap is pre-set and does not have to be re-adjusted even during longer operation. This means that malfunctions and operating errors are ruled out constructively.

ROBA®-duplostop® safety brakes switch extremely quietly due to the patented *mayr®* noise damping unit. If required by the customer, we equip the ROBA®-duplostop® with a release monitoring device. This function check of both brake circuits guarantees the highest safety for both the system and the personnel.

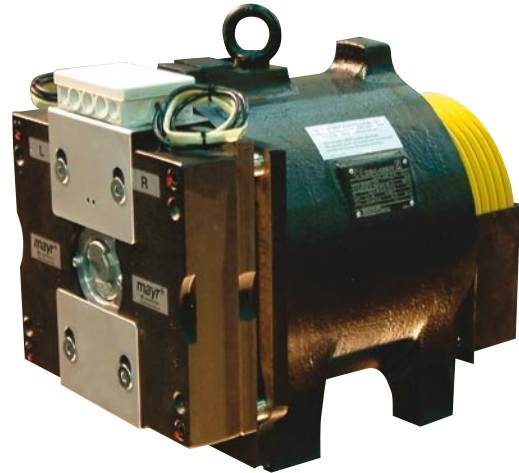
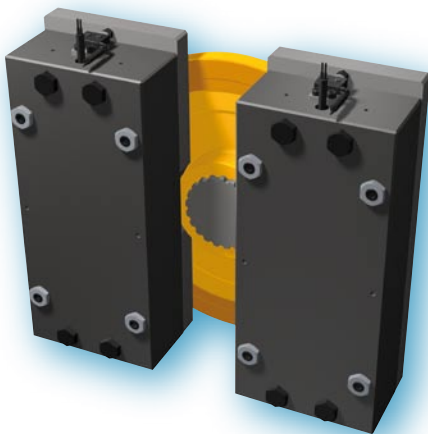

For detailed technical data, see Brochure
ROBA®-duplostop® P.8010.V0_GB

ROBA®-twinstop®

The perfect elevator brake for compact drives

The ROBA®-twinstop® consists of two independent brake circuits in one compact brake block. Therefore, this cost-effective and redundant elevator brake has an extremely short construction length. Even attachment of a compact encoder does not change the length as it is positioned in the central bore. It is possible to check both brake circuits individually electronically. For mechanical release of the brake circuit, three different variants are available.

ROBA®-twinstop® safety brakes switch extremely quietly due to the patented *mayr®* noise damping unit. Brake circuit release can be monitored using attached microswitches.



For detailed technical data, see Brochure
ROBA®-twinstop® P.8012.V0_GB

ROBA-stop®-silenzio®

The quietest safety brake for stage drives

Due to a newly developed noise damping unit, the ROBA-stop®-silenzio® in its standard version is already the quietest safety brake on the market. In new condition, the noises are < 50dB(A) (acoustic pressure level measurement). This value lies substantially below the noise level of mounted drive elements, e.g. motors and gearboxes. It is possible to reduce the noises further, subject to a surcharge. Contact

us! We will guarantee fulfilment of your noise behaviour requirements by means of a binding inspection protocol.

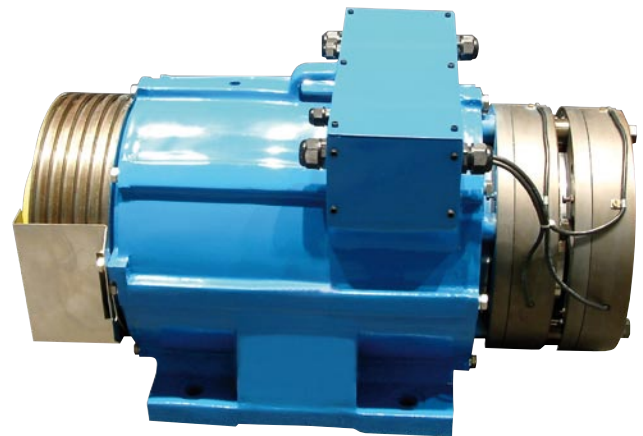
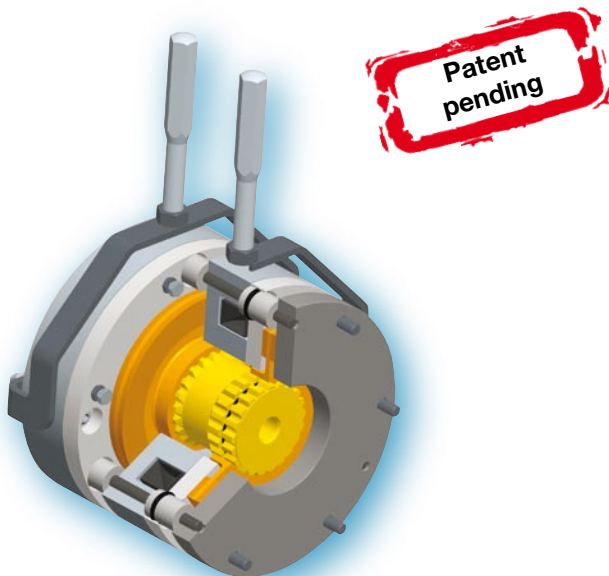

For detailed technical data, see Catalogue

ROBA-stop®-silenzio®

K.896.V0_GB

ROBA®-diskstop®

The safety system for brake disks

Arranging several ROBA®-diskstop® brakes on one brake disk is an easy way to construct redundant brake systems. This is also an attractive solution for high braking torques. When in operation, ROBA®-diskstop® brakes operate grind-free due to a patented alignment mechanism; they also switch extremely quietly.

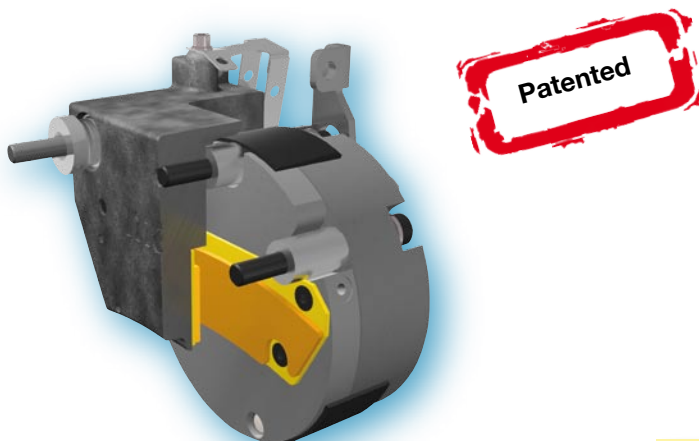

For detailed technical data, see Brochure

ROBA®-diskstop®

P.894.V0_GB

ROBA-stop®-Z

The dual-circuit safety brake with one magnetic part

The unique, patented ROBA-stop®-Z has two brake circuits working independently of each other, but only one magnetic part. This principle has proved successful in numerous applications. A hand release bracket allows mechanical brake release.

ROBA-stop®-Z can be used as protective equipment against upward-moving crashes, if it is equipped with release and temperature monitoring for checking the electric function. We also recommend a wear monitoring system.

ROBA-stop®-Z dual-circuit brakes are extremely quiet due to an extremely efficient noise damping unit. The compact design offers many opportunities for economic solutions.

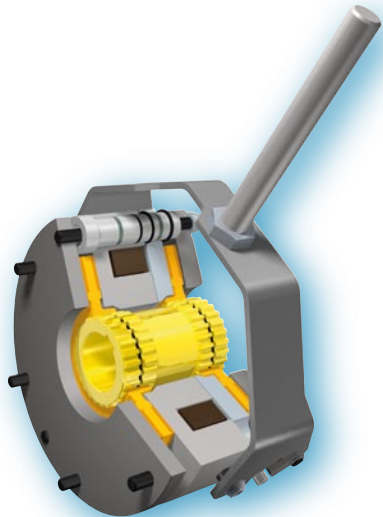

For detailed technical data, see Brochure
ROBA-stop®-Z **P.892.V0_GB**

ROBA®-sheavestop®

The reliable elevator brake for retrofitting as protection against upward travel according EN 81

According to EN-81-1, older elevator systems also require a protective assembly against excessive upward-moving cage speeds. Elevators with cantilevered traction sheaves can be easily retrofitted to the safety standard required today by attaching a ROBA®-sheavestop® safety brake.

This brake is mounted directly onto the traction sheave and is an extremely cost-efficient solution in comparison the other subsequently installable protective assemblies.

In contrast to cable brakes and safety catch devices, it provides safety against uncontrolled upward and downward trundling movements by holding reliably in the stopping place.

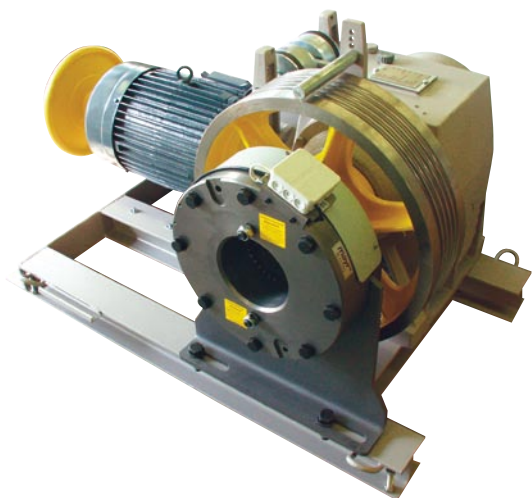

For detailed technical data, see Brochure
ROBA®-sheavestop® **P.896700.V0_GB**

ROBA-stop®-M

The robust, cost-effective mounting brake

The attractively-priced safety brakes of the ROBA-stop®-M type series are used in different elevator drive designs whenever adjustment and re-adjustment possibilities are not required.

A compact and economic solution based on tried and tested technology.

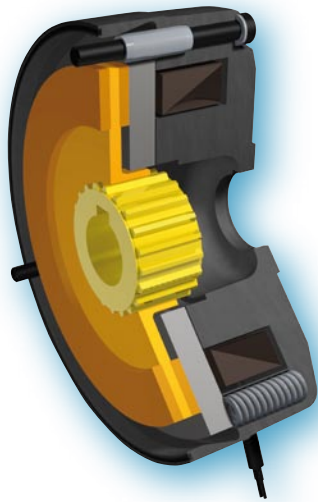

For detailed technical data, see Catalogue
ROBA-stop®-M **K.891.V0_GB**

ROBA®-quatrostop

The extremely compact multiple-circuit brake

On many systems, doubled safety via redundancy also means doubled braking torque – an extreme strain for all components.

In fact, this isn't necessary. The safety brakes of the ROBA®-quatrostop type series are redundant, but do not double the braking torque. These systems have several individually switchable and inspectable brake circuits. They **brake smoothly, are gentle on the mounting components and save costs** due to lighter connection constructions.

ROBA®-boxerstop®

The safe drum brake

The ROBA®-boxerstop® has been designed specially for conventional elevator drives with brake drums. The friction linings are adjusted optimally to the respective drum diameter. Redundant according to EN 81 via application of two or more brakes.

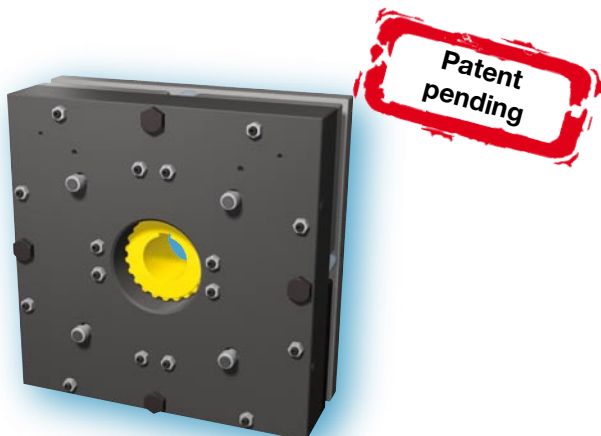

Headquarters

Chr. Mayr GmbH + Co. KG
Eichenstrasse 1, D-87665 Mauerstetten
Tel.: 0 83 41/8 04-0, Fax: 0 83 41/80 44 21
www.mayr.de, eMail: info@mayr.de



mayr[®]

Service Germany

Baden-Württemberg

Esslinger Straße 7
70771 Leinfelden-Echterdingen
Tel.: 07 11/45 96 01 0
Fax: 07 11/45 96 01 10

Bavaria

Eichenstrasse 1
87665 Mauerstetten
Tel.: 0 83 41/80 41 04
Fax: 0 83 41/80 44 23

Chemnitz

Bornaer Straße 205
09114 Chemnitz
Tel.: 03 71/4 74 18 96
Fax: 03 71/4 74 18 95

Franken

Unterer Markt 9
91217 Hersbruck
Tel.: 0 91 51/81 48 64
Fax: 0 91 51/81 62 45

Hagen

Im Langenstück 6
58093 Hagen
Tel.: 0 23 31/78 03 0
Fax: 0 23 31/78 03 25

Kamen

Lünener Strasse 211
59174 Kamen
Tel.: 0 23 07/23 63 85
Fax: 0 23 07/24 26 74

North

Schiefer Brink 8
32699 Extertal
Tel.: 0 57 54/9 20 77
Fax: 0 57 54/9 20 78

Rhine-Main

Jägerstrasse 4
64739 Höchst
Tel.: 0 61 63/48 88
Fax: 0 61 63/46 47

Branch office

China

Mayr Zhangjiagang
Power Transmission Co., Ltd.
Changxing Road No. 16,
215600 Zhangjiagang
Tel.: 05 12/58 91-75 65
Fax: 05 12/58 91-75 66
info@mayr-ptc.cn

Great Britain

Mayr Transmissions Ltd.
Valley Road, Business Park
Keighley, BD21 4LZ
West Yorkshire
Tel.: 0 15 35/66 39 00
Fax: 0 15 35/66 32 61
sales@mayr.co.uk

France

Mayr France S.A.
Z.A.L. du Minopole
BP 16
62160 Bully-Les-Mines
Tel.: 03.21.72.91.91
Fax: 03.21.29.71.77
contact@mayr.fr

Italy

Mayr Italia S.r.l.
Viale Veneto, 3
35020 Saonara (PD)
Tel.: 0 49/8 79 10 20
Fax: 0 49/8 79 10 22
info@mayr-italia.it

Singapore

Mayr Transmission (S) PTE Ltd.
No. 8 Boon Lay Way Unit 03-06,
TradeHub 21
Singapore 609964
Tel.: 00 65/65 60 12 30
Fax: 00 65/65 60 10 00
info@mayr.com.sg

Switzerland

Mayr Kupplungen AG
Tobeläckerstrasse 11
8212 Neuhausen am Rheinfall
Tel.: 0 52/6 74 08 70
Fax: 0 52/6 74 08 75
info@mayr.ch

USA

Mayr Corporation
4 North Street
Waldwick
NJ 07463
Tel.: 2 01/4 45-72 10
Fax: 2 01/4 45-80 19
info@mayrcorp.com

Representatives

Australia

Transmission Australia Pty. Ltd.
22 Corporate Ave,
3178 Rowville, Victoria
Australien
Tel.: 0 39/7 55 44 44
Fax: 0 39/7 55 44 11
info@transaus.com.au

China

Mayr Shanghai
Representative Office
Room 506, No. 1007,
Zhongshan South No. 2 Road
200030 Shanghai, VR China
Tel.: 0 21/64 57 39 52
Fax: 0 21/64 57 56 21
sales@mayr.com.cn

India

National Engineering
Company (NENCO)
J-225, M.I.D.C.
Bhosari Pune 411026
Tel.: 0 20/27 47 45 29
Fax: 0 20/27 47 02 29
nenco@nenco.org

Japan

MATSUI Corporation
2-4-7 Azabudai
Minato-ku
Tokyo 106-8641
Tel.: 03/35 86-41 41
Fax: 03/32 24 24 10
k.goto@matsui-corp.co.jp

South Africa

Torque Transfer
Private Bag 9
Elandsfontein 1406
Tel.: 0 11/3 45 80 00
Fax: 0 11/9 74 05 24
torque@bearings.co.za

South Korea

Mayr Korea Co. Ltd.
no. 302, 3rd floor, Kyoungnam
Taxi Mutual Aid Association Hall,
209-3, Myoung-Seo Dong,
Changwon, Korea
Tel.: 0 55/2 62-40 24
Fax: 0 55/2 62-40 25
info@mayrkorea.com

Taiwan

German Tech Auto Co., Ltd.
No. 162, Hsin sheng Road,
Taishan Hsiang,
Taipei County 243, Taiwan R.O.C.
Tel.: 02/29 03 09 39
Fax: 02/29 03 06 36
steve@zfgta.com.tw

Machine tools

Applications in China
Dynamic Power Transmission Co., Ltd.
Block 5th, No. 1699, Songze Road,
Xujing Industrial Zone
201702 Shanghai, China
Tel.: 021/59883978
Fax: 021/59883979
dtcshanghai@online.sh.cn

More representatives:

Austria, Benelux States, Brazil, Canada, Czech Republic, Denmark, Finland, Greece, Hongkong, Hungary, Indonesia, Israel, Malaysia, New Zealand, Norway, Philippines, Poland, Romania, Russia, Slovakia, Slovenia, Spain, Sweden, Thailand, Turkey

You can find the complete address for the representative responsible for your area under www.mayr.de in the internet.

mayr[®]
your reliable partner