

Stage Brakes

Redundant safety brakes
according to BGV C1 and EN 81

Worldwide the
No. 1
for
stage brakes

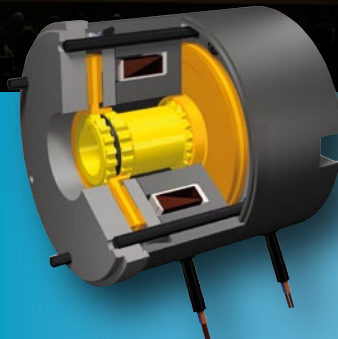

www.mayr.de

IMG.801.V02.GB

mayr[®]
your reliable partner

Construction and Development

We Always Have the Better Solution

With our innovative and economical solutions, we are able to set new records in the field of power transmission. Our ambition to always develop better solutions has made our company well-known worldwide.

Highly qualified engineers, high-performance 3D-CAD-systems and the most up-to-date FEM calculation aids used in our Development and Construction departments mean that our business is perfectly equipped to offer our customers effective solutions.



Experts for all Power Transmission Questions

Exploit our know-how, gained by decades of experience in the development, production and application of power transmission products. Our experts in Construction and Development are happy to advise you personally and competently when selecting and dimensioning the drive solution you require

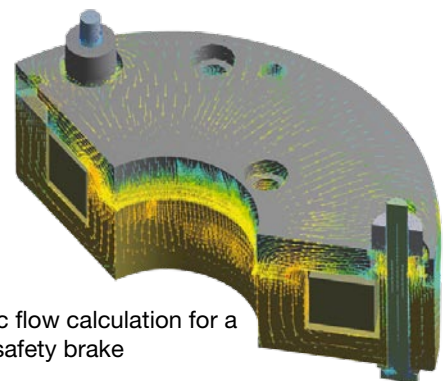

FEM-magnetic flow calculation for a ROBA-stop® safety brake

From Prototype to Finished Product

No mayr®-product is released onto the market until it has proved its functional capabilities and reliability in extreme, long-term test.

The spectrum of testing stands is as varied as our range of products:

- Friction work test stands
- Wear test stands
- Noise measurement room with highly accurate noise measurement inspection devices
- Torque measurement stands up to 200.000 Nm
- Impact and alternating load test stands
- Force test stands
- Linear movement test stands
- Continuous performance test stands
- Magnetic flow measurement test stands
- High-speed test stands up to 20.000 rpm
- Misalignment and angular misalignment test stands
- Load and measurement test stands for DC motors

Product Data: Our 24-hour Service

Our website offers you detailed information 24 hours per day, 365 days per year with no delays. Here you can find not only the latest catalogues and technical documentation, but also CAD-files for cost-saving construction of our products



100 % quality: Before delivery, every single brake is checked and the results are recorded.

Trust in the reliability and expertise of the worldwide market leader!

Low-noise stage brakes by *mayr*[®] power transmission make a daily appearance at numerous events in very different places around the globe.

We have the optimum stage brake for your application:

- Low-noise safety brakes**
- Redundant brake systems without doubling the braking torque**
- Perfect double brakes for chain hoists and hoisting devices**
- Radially mountable brake systems for disk brakes**
- small-dimensioned dual-circuit brakes with minimum space requirements**
- Efficient linear brakes for axial movements**
- Safety brakes in a double package for gearless application**

Safety requires a reliable and competent partner

Where safety is concerned, compromises are out of the question. *mayr*[®] power transmission is your reliable and competent partner for the development, production and implementation of safety brakes in theatre, film and stage institutions. We offer innovative, state-of-the-art technology and local representation in every important industrial region worldwide. Based on 40 years of know-how in the field of safety brakes, our experience with thousands of different applications and our extensive product range, we are able to offer you the perfect, cost-effective and extremely low-noise solution for your specific demands.



ROBA-stop®-silenzio®

The quietest safety brake for stage drives

Due to a newly developed noise damping unit, the ROBA-stop®-silenzio® in its standard version is already the quietest safety brake on the market. In new condition, the noises are < 50dB(A) (acoustic pressure level measurement).

This value lies substantially below the noise level of mounted drive elements, e.g. motors and gearboxes. It is possible to reduce the noises further, subject to a surcharge. Contact us! We will guarantee fulfilment of your noise behaviour requirements by means of a binding inspection protocol.

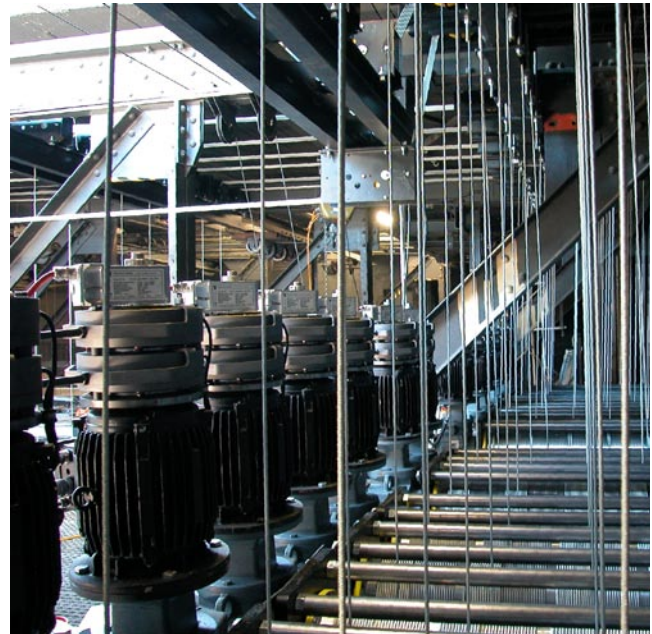
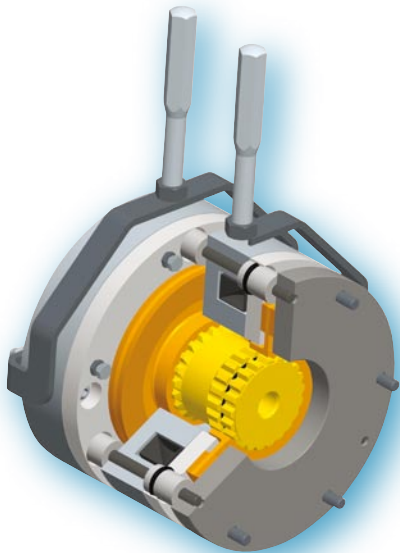

For detailed technical data, see Catalogue
ROBA-stop®-silenzio® K.896.V0_GB

ROBA®-secustop

The perfect double brake for chain hoists and hoisting devices according to BGV C1 and EN 81

The ROBA®-secustop consists of two independent DC brakes. This means it is also suitable for chain hoists according to the standards BGV D8 Plus and even BGV C1. Easy installation without any adjustment work means high operational safety

The ROBA®-secustop is mainly maintenance-free due to wear-resistant and long-lasting friction linings. An integrated damping system reduces the switching noises. In order to guarantee the highest possible operational safety and reliability, every single brake is subjected to a 100 % inspection at the factory before delivery

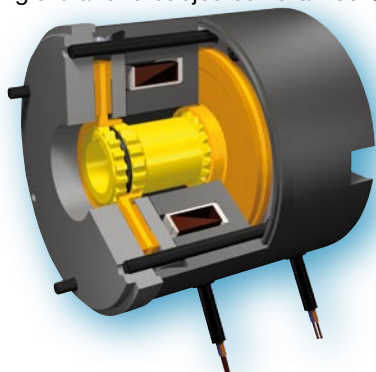

For detailed technical data, see Brochure
ROBA®-secustop P.8020.V0_GB

Stage brakes

Double the safety without double the braking torque

Worldwide innovation

Having double the safety via redundancy also means doubling the braking torque in many systems – an enormous strain for all components. It doesn't have to be that way. The patented safety brakes

ROBA®-diskstop® and ROBA®-duplostop® SO are redundant without doubling the braking torque. These **systems brake smoothly, conserve the mounting components and save costs** due to easier connection constructions.

ROBA®-duplostop® SO

The extremely compact multiple-circuit brake

The ROBA®-duplostop® SO is an especially short, redundant stage brake with low braking torque increase. It is extremely quiet due to a patented noise damping unit. All brake circuits can be switched and inspected individually.

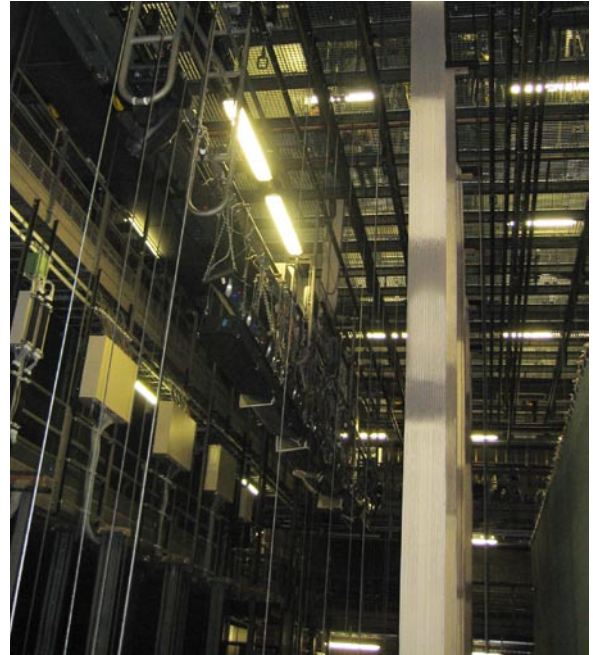
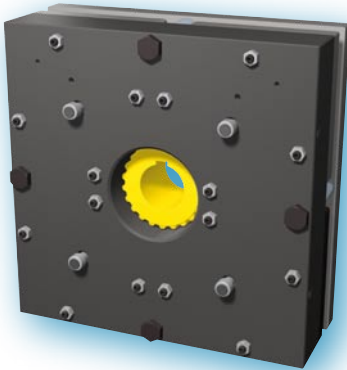

ROBA®-diskstop®

The safety system for brake disks

Positioning several ROBA®-diskstop® brakes on one brake disk is an easy way to build up redundant brake systems with a low braking torque increase. This is also an attractive solution for high braking torques.

When in operation, ROBA®-diskstop® brakes operate grind-free due to a patented alignment mechanism; they also switch extremely quietly.

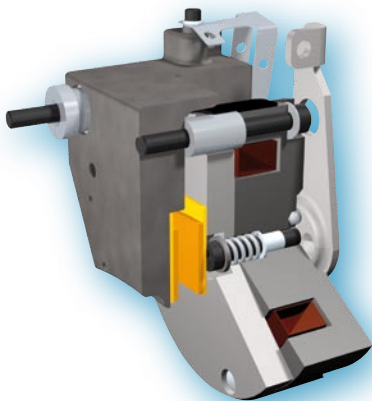

Example:

On the stage winch, 5 ROBA®-diskstop® brakes generate the required braking torque. A sixth redundant brake guarantees the necessary safety. The braking torque increases by only 20 percent.

For detailed technical data, see Brochure
ROBA®-diskstop® P.894.V0_GB

ROBA®-duplostop®

The safety brake in a double package for gearless winches

The ROBA®-duplostop® consists of two individual, rectangular brakes, which are positioned next to one another. Therefore, it has an extremely short construction length in comparison to systems with brakes that are positioned end-to-end. The compact constructive design makes installation and handling easier. The working air gap is pre-set and does not have to be re-adjusted even during longer operation. This means that malfunctions and operating errors are ruled out constructively.

ROBA®-duplostop® safety brakes switch extremely quietly due to the patented mayr® noise damping unit. If required by the customer, we equip the ROBA®-duplostop® with a release monitoring device. This function check of both brake circuits guarantees the highest safety for both the system and the personnel.

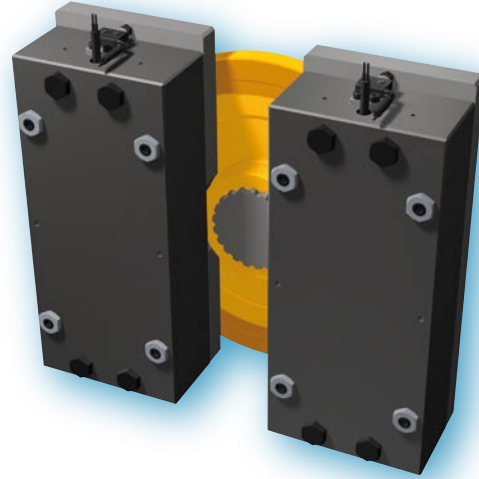
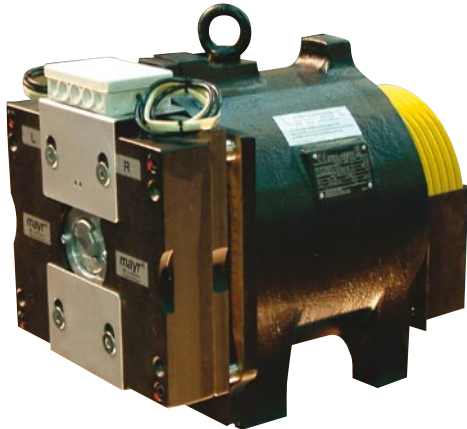

For detailed technical data, see Brochure
ROBA®-duplostop® **P.8010.V0_GB**

ROBA-stop®-Z

The dual-circuit safety brake with one magnetic part

The unique, patented ROBA-stop®-Z has two brake circuits working independently from each other, but only one magnetic part. This principle has proven successful in numerous applications. A hand release bracket allows mechanical brake release.

ROBA-stop®-Z dual-circuit brakes are equipped with release monitoring and, if necessary, temperature monitoring. This means that they are approved for stage-technological drives according to BCV C1, DIN 56925 and DIN 56921-11.

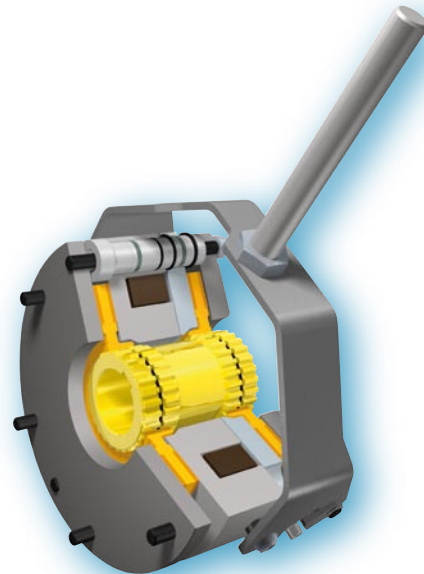
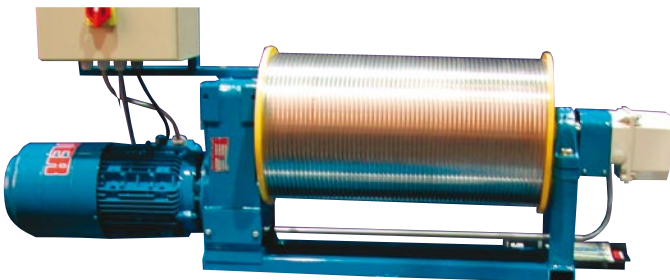

For detailed technical data, see Brochure
ROBA-stop®-Z **P.892.V0_GB**

Extremely low-noise theatre brakes in special designs

Apart from our versatile standard Type series, we also develop and manufacture many different application-optimised safety brakes for stage technology. We would be happy to assist you in finding an individually optimised solution for your application. Contact your local mayr® partner or our specialists at our headquarters to talk about your project and benefit from our extensive know-how in the field of safety brakes.



Electrical Control

We have the optimum control devices for your stage brakes. They are adapted to the respective design and complement the brakes perfectly.



Further *mayr*®-Stage Technology Products

- ❑ **ROBA®-DS**
backlash-free shaft coupling for below-stage machinery



- ❑ **EAS®**
perfect overload protection for many areas



- ❑ **ROBA®-ES**
backlash-free shaft coupling for tubular shaft hoists



- ❑ **smartflex®**
backlash-free shaft coupling for angular gearboxes



- ❑ **ROBA®-contitorque**
continuous slip clutch for equipment and performer flying



- ❑ **ROBA®-linearstop**
brake system for lifting podiums





Headquarters

Chr. Mayr GmbH + Co. KG
Eichenstrasse 1, D-87665 Mauerstetten
Tel.: 0 83 41/8 04-241, Fax: 0 83 41/80 44 22
www.mayr.de, eMail: info@mayr.de



mayr®

Service Germany

Baden-Württemberg

Esslinger Straße 7
 70771 Leinfelden-Echterdingen
 Tel.: 07 11/45 96 01 0
 Fax: 07 11/45 96 01 10

Bavaria

Eichenstrasse 1
 87665 Mauerstetten
 Tel.: 0 83 41/80 41 04
 Fax: 0 83 41/80 44 23

Chemnitz

Bornaer Straße 205
 09114 Chemnitz
 Tel.: 03 71/4 74 18 96
 Fax: 03 71/4 74 18 95

Franken

Unterer Markt 9
 91217 Hersbruck
 Tel.: 0 91 51/81 48 64
 Fax: 0 91 51/81 62 45

Hagen

Im Langenstück 6
 58093 Hagen
 Tel.: 0 23 31/78 03 0
 Fax: 0 23 31/78 03 25

Kamen

Lünener Strasse 211
 59174 Kamen
 Tel.: 0 23 07/23 63 85
 Fax: 0 23 07/24 26 74

North

Schiefer Brink 8
 32699 Extertal
 Tel.: 0 57 54/9 20 77
 Fax: 0 57 54/9 20 78

Rhine-Main

Jägerstrasse 4
 64739 Höchst
 Tel.: 0 61 63/48 88
 Fax: 0 61 63/46 47

Branch office

China

Mayr Zhangjiagang
 Power Transmission Co., Ltd.
 Changxing Road No. 16,
 215600 Zhangjiagang
 Tel.: 05 12/58 91-75 62
 Fax: 05 12/58 91-75 66
 info@mayr.cn

Great Britain

Mayr Transmissions Ltd.
 Valley Road, Business Park
 Keighley, BD21 4LZ
 West Yorkshire
 Tel.: 0 15 35/66 39 00
 Fax: 0 15 35/66 32 61
 sales@mayr.co.uk

France

Mayr France S.A.
 Z.A.L. du Minopole
 BP 16
 62160 Bully-Les-Mines
 Tel.: 03.21.72.91.91
 Fax: 03.21.29.71.77
 contact@mayr.fr

Italy

Mayr Italia S.r.l.
 Viale Veneto, 3
 35020 Saonara (PD)
 Tel.: 0 49/8 79 10 20
 Fax: 0 49/8 79 10 22
 info@mayr-italia.it

Singapore

Mayr Transmission (S) PTE Ltd.
 No. 8 Boon Lay Way Unit 03-06,
 TradeHub 21
 Singapore 609964
 Tel.: 00 65/65 60 12 30
 Fax: 00 65/65 60 10 00
 info@mayr.com.sg

Switzerland

Mayr Kupplungen AG
 Tobelackerstrasse 11
 8212 Neuhausen am Rheinfall
 Tel.: 0 52/6 74 08 70
 Fax: 0 52/6 74 08 75
 info@mayr.ch

USA

Mayr Corporation
 4 North Street
 Waldwick
 NJ 07463
 Tel.: 2 01/4 45-72 10
 Fax: 2 01/4 45-80 19
 info@mayrcorp.com

Representatives

Australia

Transmission Australia Pty. Ltd.
 22 Corporate Ave,
 3178 Rowville, Victoria
 Australien
 Tel.: 0 39/7 55 44 44
 Fax: 0 39/7 55 44 11
 info@transaus.com.au

Brasilien

Automotion Ltda.
 Acesso Jose Sartorelle, KM 2.1
 18550-000 Boituva-SP
 Brasilien
 Tel.: 015/33639900
 Fax: 015/33639911
 comex@automotion.com.br

China

Mayr Shanghai
 Representative Office
 Room 506, No. 1007,
 Zhongshan South No. 2 Road
 200030 Shanghai, VR China
 Tel.: 0 21/64 57 39 52
 Fax: 0 21/64 57 56 21
 sales@mayr.com.cn

India

National Engineering
 Company (NENCO)
 J-225, M.I.D.C.
 Bhosari Pune 411026
 Tel.: 0 20/27 47 45 29
 Fax: 0 20/27 47 02 29
 nenco@nenco.org

Japan

MATSUI Corporation
 2-4-7 Azabudai
 Minato-ku
 Tokyo 106-8641
 Tel.: 03/35 86-41 41
 Fax: 03/32 24 24 10
 k.goto@matsui-corp.co.jp

Polen

Wamex Sp. z o.o.
 ul. Pozaryskiego, 28
 04-703 Warszawa
 Polen
 Tel.: 022/6159080
 Fax: 022/6159081
 wamex@wamex.com.pl

South Korea

Mayr Korea Co. Ltd.
 no. 302, 3rd floor, Kyoungnam
 Taxi Mutual Aid Association Hall,
 209-3, Myoung-Seo Dong,
 Changwon, Korea
 Tel.: 0 55/2 62-40 24
 Fax: 0 55/2 62-40 25
 info@mayrkorea.com

Taiwan

German Tech Auto Co., Ltd.
 No. 162, Hsin sheng Road,
 Taishan Hsiang,
 Taipei County 243,
 Taiwan R.O.C.
 Tel.: 02/29 03 09 39
 Fax: 02/29 03 06 36
 steve@zfgta.com.tw

More representatives:

Austria, Benelux States, Canada, Czech Republic, Denmark, Finland, Greece, Hongkong, Hungary, Indonesia, Israel, Malaysia, New Zealand, Norway, Philippines, Romania, Russia, Slovakia, Slovenia, South Africa, Spain, Sweden, Thailand, Turkey

You can find the complete address for the representative responsible for your area under www.mayr.de in the internet.

mayr®
 your reliable partner