

Manufacturer's Declaration

This product is intended for installation in a machine or system, based on the machine directive 98/37/EC.

It is forbidden to start use of the product until the machine or system into which it should be built is operating in accordance with the EC directives.

The product corresponds to the low voltage directive 73/23/EEC.



Safety Regulations

Danger!

To prevent injury or damage, only professionals and specialists should work on the devices, following the relevant standards and directives. Please read the Installation and Operational Instructions carefully before installation and initial operation of the device.



Warning:

Without a conformity inspection, this product is not suitable for use in areas where there is a high danger of explosion. This statement is based on directive 94/9 EC (ATEX directive).

Application

This device is used to start and stop mayr® ROBA®-takt circuit modules and mayr®-clutch brake combinations.

It can be used for alternating 24 VDC coil switching, if a 24 VDC power supply is available.

Function

1-sensor operation: -activated- clutch is energised
-deactivated- brake is energised

The respective control of the clutch or brake is indicated via LED. The ROBA®-takt circuit module has no over-excitation function.

The brake has priority: The brake is energised independently of the sensor position when the 24 VDC power supply is switched on. The coil is energised with the 24 VDC power supply.

Slope separation: To avoid simultaneous clutch and braking torques, a slope separation of 0 - 100 ms between clutch and brake can be set, which acts according to the respective rise time and drop-out time of the coils (see switching time table). This adjustment is carried out via the potentiometers Ku = clutch (P2) and Br = brake (P1). The factory default setting is 0 ms.

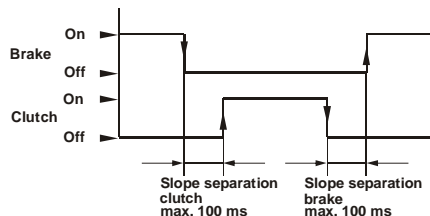

Technical Data

| | |
|-------------------------|--|
| Input voltage | 24 VDC SELV/PELV ripple content ≤5% |
| Recommended fuse | T 4A |
| Output voltage | 24 VDC |
| Output power | max. 79 W |
| Slope separation | 0 - 100 ms (factory default setting is 0 ms) |
| Ambient temperature | 0 °C - +70 °C |
| Storage temperature | -20 °C - +85 °C |
| Conductor cross section | 0.14 - 1.5 mm ² / AWG 26-14 |
| Protection | IP 00 |
| Design | Printed board with screw-on attachment part or a mounting frame for 35 mm standard mounting rails. |

| | | | |
|--------------------------------|-------|-------|--------------|
| Max. cycle frequencies: | 45 °C | 70 °C | |
| up to 1 A / sizes 3 + 4 | 600 | 600 | cycles / min |
| approx. 2 A / sizes 5 + 6 | 240 | 180 | cycles / min |
| approx. 3 A / size 7 | 120 | 75 | cycles / min |

Please Observe:

Higher cycle frequencies will lead to ROBA®-takt circuit module overload and failure.



Dimensions with Mounting Frame (mm)

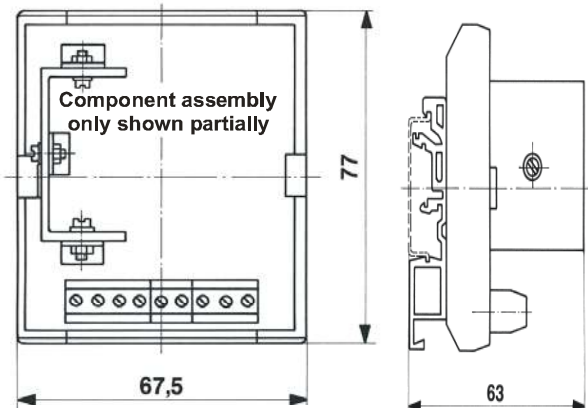

Electrical Connection (Terminals)

- 1 24 VDC input voltage
- 2 GND input voltage
- 3+4 brake
- 5+6 clutch
- 7 12 VDC control voltage for switches or sensors
- 8+9 control inputs, see Wiring Diagram

Wiring Example

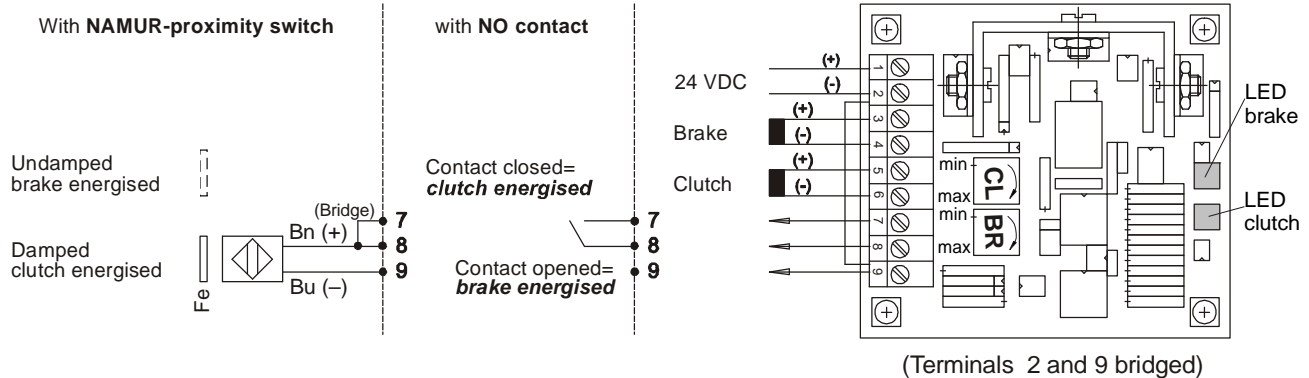

Table Switching Times

| ROBA® -takt size | | 3 | 4 | 5 | 6 | 7 | |
|---|---|----------------------|---------------------|--------------------|---------------------|---------------------|-------|
| Switching times [s] | Without overexcitation | t ₁₁ Cl | 0.010 | 0.015 | 0.020 | 0.030 | 0.045 |
| | | t ₁ Cl | 0.045 | 0.065 | 0.080 | 0.150 | 0.200 |
| | | t ₁₁ Br | 0.006 | 0.008 | 0.010 | 0.015 | 0.025 |
| | | t ₁ Br | 0.035 | 0.040 | 0.055 | 0.100 | 0.150 |
| | | t ₂ Cl | 0.012 | 0.020 | 0.045 | 0.060 | 0.090 |
| | | t ₂ Br | 0.010 | 0.018 | 0.030 | 0.060 | 0.090 |
| | With overexcitation (only switch-on time) | t ₁₁ Cl | 0.003 | 0.005 | 0.007 | 0.010 | 0.015 |
| | | t ₁ Cl | 0.025 | 0.035 | 0.040 | 0.075 | 0.100 |
| t ₁₁ Br | | 0.002 | 0.003 | 0.004 | 0.006 | 0.008 | |
| t ₁ Br | | 0.020 | 0.022 | 0.030 | 0.050 | 0.075 | |
| Recommended overexcitation period [ms] | | 10 * | 10 * | 10 | 15 | 20 | |
| Min. required slope separation [ms] | with overexcitation | 20 | 25 | 30 | 80 | 120 | |
| | without overexcitation | 0 | 0 | 15 | 50 | 80 | |
| Magnitude of overexcitation c. 10 x nominal voltage (limited current) | | | | | | | |
| Permitted friction work for one single switching Q _E [J] | | 3.8x10 ³ | 6.2x10 ³ | 9x10 ³ | 15x10 ³ | 25x10 ³ | |
| Total friction work Q _{tot} [J] | | 22.5x10 ⁷ | 44x10 ⁷ | 87x10 ⁷ | 171x10 ⁷ | 340x10 ⁷ | |

