



## Guidelines on the Declaration of Conformity

A conformity evaluation has been carried out for the product in terms of the EU Low Voltage Directive 2014/35/EU and the Electromagnetic Compatibility (EMC) Directive 2014/30/EU. The Declaration of Conformity is laid out in writing in a separate document and can be requested if required.

## Guidelines on the EMC Directive (2014/30/EU)

The product cannot be operated independently according to the EMC directive. Only after integration of the product into an overall system can this be evaluated in terms of the EMC. For electronic equipment, the evaluation has been verified for the individual product in laboratory conditions, but not in the overall system.

## Guidelines on the Machinery Directive (2006/42/EC)

The product is a component for installation into machines according to the machinery directive 2006/42/EC. The product can fulfil the specifications for safety-related applications in coordination with other elements. The type and scope of the required measures result from the machine risk analysis. The product then becomes a machine component and the machine manufacturer assesses the conformity of the safety device to the directive. It is forbidden to start use of the product until you have ensured that the machine accords with the regulations stated in the directive.

## Guidelines on the ATEX Directive

Without a conformity evaluation, this product is not suitable for use in areas where there is a high danger of explosion. For application of this product in areas where there is a high danger of explosion, it must be classified and marked according to directive 2014/34/EU.

## Safety and Guideline Signs

### Danger



Immediate and impending danger, which can lead to severe physical injuries or to death.

### CAUTION



Danger of injury to personnel and damage to machines.



Guidelines on important points.

## General Safety Guidelines

### DANGER



Danger of death! Do not touch voltage-carrying lines and components.

### DANGER



Danger of burns when touching hot surfaces

### CAUTION



- Danger from devices caused by short-circuits and earth short-circuits at the terminals
- Electronic devices cannot be guaranteed fail-safe.

During the risk assessment required when designing the machine or system, the dangers involved must be evaluated and removed by taking appropriate protective measures.

To prevent injury or damage, only professionals and specialists are allowed to work on the devices. They must be familiar with the dimensioning, transport, installation, initial operation, maintenance and disposal according to the relevant standards and regulations.

## General Safety Guidelines



Only carry out installation, maintenance and repairs in a de-energised, disengaged state and secure the system against inadvertent switch-on.



Before product installation and initial operation, please read the Installation and Operational Instructions carefully and observe the Safety Regulations. Incorrect operation can cause injury or damage.

# Installation and Operational Instructions for ROBA®-switch 24 VDE Type 018.100.2

(B.0181002.EN)

## Application

ROBA®-switch 24 VDC fast switching modules are used to operate DC consumers with overexcitation or power reduction, for example electromagnetic brakes and clutches (ROBA-stop®, ROBA®-quick, ROBATIC®), electromagnets, electrovalves, etc.

### Fast switching module ROBA®-switch 24 VDC 018.100.2

- Consumer operation with overexcitation or power reduction
- Integrated DC-side disconnection (shorter connection time  $t_c$ )
- Input voltage: 24 VDC
- Maximum output current I: 5 A
- UL-approved



### CAUTION



The ROBA®-switch 24 VDC with integrated DC-side disconnection is not suitable for being the only safety disconnection in applications!

## Function

The ROBA®-switch 24 VDC units are used for an input voltage of 24 VDC. They can switch internally, meaning that the output voltage switches to holding voltage from the input voltage (=overexcitation voltage) via pulse-width modulation using 20 kHz. The overexcitation time can be adjusted via a DIP switch to 150 ms, 450 ms, 1 s, 1.5 s and 2.15 s. The holding voltage can be adjusted via a further DIP switch to  $\frac{1}{4}$ ,  $\frac{1}{3}$ ,  $\frac{1}{2}$  and  $\frac{2}{3}$  of the input voltage (equals 6 VDC, 8 VDC, 12 VDC and 16 VDC at an input voltage of 24 VDC).

In addition, the ROBA®-switch 24 VDC features integrated DC-side disconnection. In contrast to the usual DC-side disconnection, no further protective measures or external components are required. The DC-side disconnection is activated in standard mode and causes short switching times on the electromagnetic consumer. This can, however, be deactivated by installing a bridge between terminals 7 and 8 in order to produce soft brakings and quieter switching noises. However, this substantially lengthens the switching times (approx. 6 – 10x).

## Electrical Connection (Terminals)

- 2 + 3 Input voltage, ground
- 4 Control input
- 5 – 7 Input voltage +24 VDC
- 8 + 9 Output voltage +
- 10 Output voltage -

## Dimensions (mm)

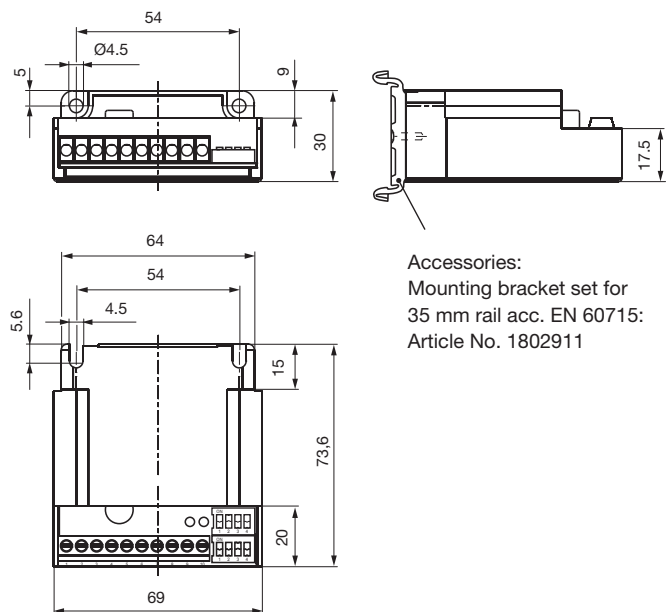

Accessories:  
Mounting bracket set for  
35 mm rail acc. EN 60715:  
Article No. 1802911

# Installation and Operational Instructions for ROBA®-switch 24 VDE Type 018.100.2

(B.0181002.EN)

Technical Data				Type 018.100.2 Sizes 1
Input voltage	+ 20% / - 10% SELV/PELV, ripple content ≤ 5%	$U_i$	[VDC]	24
Output voltage		$U_o$	[VDC]	Input voltage $U_i$
	± 20%	$U_H$	[VDC]	$\frac{1}{4}, \frac{1}{3}, \frac{1}{2}, \frac{2}{3} \times U_i$
Output current	at ≤ 45 °C	I	[A]	5.0
	at max. 70 °C	I	[A]	2.5
Device fuses				F 12.5 A (5 x 20 mm)
Protection				IP00
Terminals				Nominal cross-section 1.5 mm <sup>2</sup> (AWG 22-14), screws M3, max. tightening torque 0.5 Nm
Ambient temperature			[°C]	-25 to +70
Storage temperature			[°C]	-40 to +105
Conformity markings				
Installation conditions				The installation position can be user-defined. Please ensure sufficient heat dissipation and air convection! Do not install near to sources of intense heat!

## Wiring Example

- fast switch-off via integrated DC-side disconnection
- power-free switching via control input

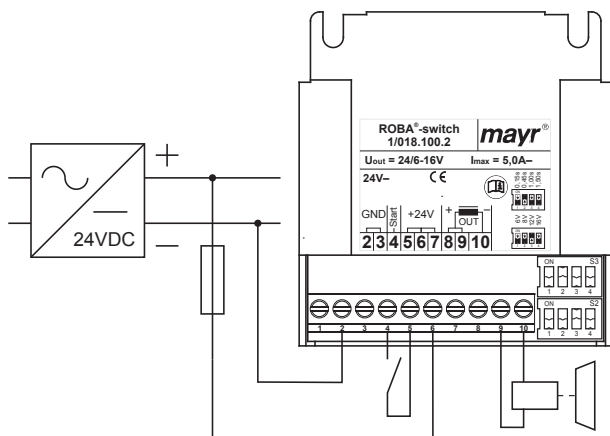

## Wiring Example

- slow switch-off (freewheeling)
- control via contactor in power supply cable

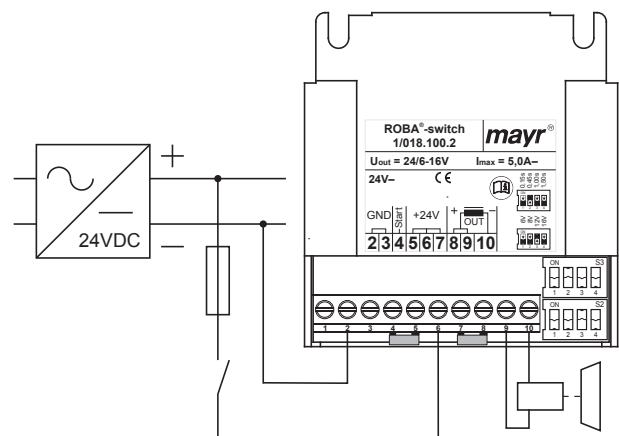

## Switch-ON

Switch-on can take place by switching the supply voltage or via a power-free control input (terminal 4). The current consumption is approx. 10 mA. A green light-emitting diode emits a signal when the device is switched on. After switching from overexcitation voltage to holding voltage, the diode continues glowing with reduced intensity.

## Switch-OFF



If short switching times are required, please switch DC-side. Here, the ROBA®-switch 24 VDC limits the switch-off voltage to approx. 70V. DC-side disconnection is signaled by the red light-emitting diode flashing at the moment of switch-off.

If a longer brake engagement time or a quieter switching noise is required, please switch freewheeling. For this, a bridge must be installed between terminals 7 and 8.

## Device Fuses

To protect against damage from short-circuits or earth short-circuits, please add suitable device fuses to the mains cable.

Short-circuits or earth short-circuits can lead to ROBA®-switch failures. After fuse elements have reacted to a malfunction, the ROBA®-switch 24 VDC must be checked for functional and operational safety (overexcitation voltage, switch-off voltage, response delay time, holding voltage). The same procedure is to be carried out after coil failure.

## Overexcitation

On overexcitation, the brake is initially energised with a voltage higher than the nominal voltage. This decreases the separation time  $t_2$ .



Increased wear (enlarged air gap) as well as coil heat-up lengthen the brake separation time  $t_2$ . Therefore, when dimensioning the overexcitation time  $t_o$ , please select at least double the separation time  $t_2$  on each brake Type and size (catalogue values).

The overexcitation time can be adjusted via the DIP switch S3 to 150 ms, 450 ms, 1 s, 1.5 s and 2.15 s  $\pm$  20 %. The switches may only be switched in de-energised state and may only be adjusted as depicted.

DIP switch	Overexcitation time $t_o$ [s]
	0.15
	0.45
	1.00
	1.50
	2.15

Manufacturer-side

## Holding Voltage

The holding voltage can be adjusted via the DIP switch S2 to  $\frac{1}{4}$ ,  $\frac{1}{3}$ ,  $\frac{1}{2}$  and  $\frac{2}{3}$  of the input voltage  $U_i$ . The switches may only be switched in de-energised state and may only be adjusted as depicted. Each stated holding voltage corresponds to an input voltage of 24 VDC.

DIP switch	Holding voltage $U_H$ [VDC]
	$\frac{1}{4} \times U_i$ 6
	$\frac{1}{3} \times U_i$ 8
	$\frac{1}{2} \times U_i$ 12
	$\frac{2}{3} \times U_i$ 16

Manufacturer-side

## Recovery Time 100 ms

The recovery time is the amount of time the ROBA®-switch 24 VDC requires in order to reach its starting position after switch-off. Therefore, the device may be switched on again at the earliest after 100 ms.

During cycle operation, please take suitable measures to ensure that the recovery time of 100 ms is maintained.

## Coil Capacity

The values for the **maximum coil nominal capacity** stated in the Table are guideline values for a switching frequency of maximum 1 cycle per minute and for maintenance of the permitted current I.

Size	Holding voltage $U_H$ [VDC]	Coil nominal voltage $U_N$ [VDC]	Coil nominal capacity $P_N$		Operation with	
			Type 018.100.2		over-excitation	Power reduction
			$\leq 45\text{ °C}$	70 °C		
			[W]			
1	6	6	30	15	x	
		8	53	27	x	x
		12	120	60	x	x
		16	213	107	x	x
		24	480	240		x
	8	8	40	20	x	
		12	90	45	x	x
		16	160	80	x	x
		24	360	180		x
	12	12	60	30	x	
		16	107	53	x	x
		24	240	120		x
	16	16	80	40	x	
		24	180	90		x



If the switching frequency is larger than 1 cycle per minute or if the overexcitation time  $t_o$  is longer than double the separation time  $t_2$ , please observe the following:

$$P \leq P_N$$

The coil capacity P must not be larger than  $P_N$  or the nominal current left which flows through the ROBA®- switch 24 VDC must not be exceeded, as otherwise the coil and the ROBA®- switch 24 VDC can fail due to thermal overload.

### Time Diagram:

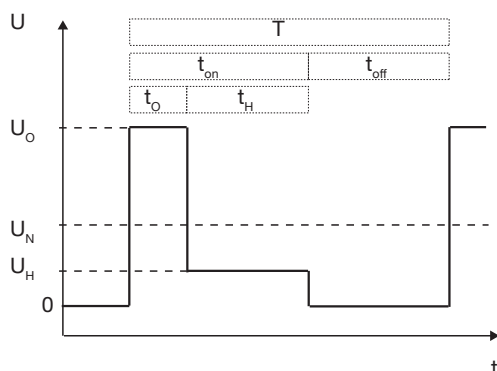

### Calculations:

P [W] RMS coil capacity dependent on switching frequency, overexcitation, reduction in capacity and duty cycle

$$P = \frac{P_o \times t_o + P_H \times t_H}{T}$$

$P_N$  [W] Coil nominal capacity (catalogue values, Type tag)

$P_o$  [W] Coil capacity on overexcitation

$$P_o = \left( \frac{U_o}{U_N} \right)^2 \times P_N$$

$P_H$  [W] Coil capacity at reduced capacity

$$P_H = \left( \frac{U_H}{U_N} \right)^2 \times P_N$$

$t_o$  [s] Overexcitation time

$t_H$  [s] Time of operation with reduction in capacity

$t_{off}$  [s] Time without voltage

T [s] Total time ( $t_o + t_H + t_{off}$ )

$U_o$  [V] Overexcitation voltage

$U_H$  [V] Holding voltage

$U_N$  [V] Coil nominal voltage

I [A] RMS current dependent on switching frequency, overexcitation time and duty cycle

$$I = \sqrt{\frac{P \times P_N}{U_N^2}}$$

## EMC-compatible Installation



- Avoid an antennae effect: Keep the supply cables as short as possible; do not form rings or loops with the cables!
- Mount good earth connections onto the metal body of the brake!
- Lay control cables separately from power cables or from strongly pulsating supply cables!
- During operation with a frequency converter, please ensure EMC-compatible installation of the frequency converter!
- Please always check the holding voltage of the ROBA®-switch 24V during operation of all components in the system.

## Standards

### Product standard

VDE 0160/DIN EN 50178:1998-04

Electronic equipment for use in power installations

### EMC inspections

EN 61000-6-2:2006-03

Interference immunity

EN 61000-6-4:2007-09

Interference emission

### Insulation coordination

acc. VDE 0110 / EN 60664:2008-01

Pollution degree 2

Rated insulation voltage 60 VDC

## Intended Use

*mayr*®-rectifiers have been developed, manufactured and tested as electronic equipment in compliance with the DIN EN 50178 standard and in accordance with the EU Low Voltage Directive. During installation, operation and maintenance of the product, the requirements for the standard must be observed. *mayr*®-rectifiers are for use in machines, systems and devices and must only be used in the situations for which they are ordered and confirmed. The products are designed for installation into electrical control cabinets and terminal boxes. Using them for any other purpose is not allowed.